

Table of Contents

Chapter 1	Product Introduction	2
1.1	Product Introduction	2
1.2	Nameplate Description	3
1.3	Model Description	3
1.4	Operating Environment.....	4
Chapter 2	Wiring Description.....	5
2.1	Basic wiring diagram.....	5
2.2	Main circuit terminal and wiring	7
Chapter 3	Description on Digital Operator Keystrokes	11
3.1	Connection introduction of operaton and display.....	11
3.2	Explanation for the digital operation controller	12
3.3	Check for the status parameter	13
3.4	Password setting	13
Chapter4	Auto-tunning	14
Chapter5	Fault diagnosis and countermeasures	15
Chapter6	Standard Specifications	53
Chapter7	Appendix	57

Chapter 1 Product Introduction

1.1 Product Introduction

Thank you for purchasing AXXX Current Torque Vector Control General-Purpose Inverters developed by Qma Technical Company, featuring high performance and low noise. Please read this manual thoroughly and carefully to make good use of the performance and functions of this inverter and to keep your safety in operation. Please contact our agents in your regions or technical personnel of engineering department in our company if any problem you can't solve by referring to the manual occurs in operation. Our professionals are ready to help you. You are welcome to use our products.

[Notice]:

“Danger” “Caution” in the manual prospect you the security precautions in moving, installing, operating and checking.

[Danger]: The misuse may lead to personal injury. Please don't take down, install or change the internal parts, circuitries or links of the inverter without permission.

[Caution]: The misuse may lead to the damage of the inverter or mechanical system.

[Danger]:

- Please don't touch circuit boards, parts or components after power-off before the “Charge” led is off.
- Please don't take down, install or change the internal parts, circuits or links without permission in the inverter.
- Please don't take wiring when power is supplied; please don't check the components, parts or signals on the circuit board when the inverter is running.
- Please correctly ground the earth terminals of the inverter: 220V terminal: the third grounding; 440V: special grounding.

[Caution]:

- Please don't carry on withstand voltage test on internal parts or components of the inverter, because these semi-conduct parts or components are subject to be damaged by high voltage.
- You mustn't connect the output terminals of the inverter U, V, W to the input terminals AC power source (R, S, T).
- Please don't touch the main circuit board for the CMOSIC component on the circuit board of the inverter is subject to affected or damaged by static electricity

[Security Precaution in Operation]

Danger

- Please don't take off the front cover when the inverter is powered for fear of electric shock
- Please don't approach to the machine if you set the automatic restart function, because the motor will be restarted after the machine stop.
- The “Stop” switch function is available after setting. It is different from urgent “Stop” switch in use, please pay attention to it.

Caution

- Please don't touch the hot components such as radiator and brake resistor for fear of scald and electric shock.
- Please input the permissible range of the motor and the machine, because it is easy for the inverter to rise speed from low to high.
- Please pay attention to the relative settings when using the brake.
- Please don't test the signal on the circuit board when the inverter is running.
- Please don't discretionarily adjust the parameters, because the inverter was set well before leaving factor.

1.2 Nameplate Description

Take 1HP220V as an example:

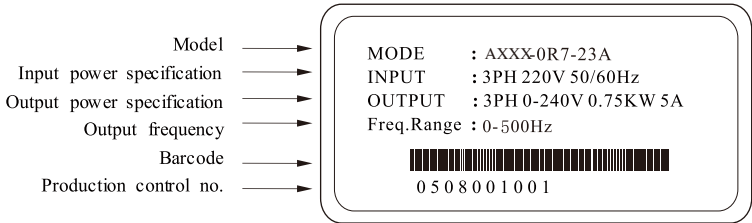

1.3 Model Description

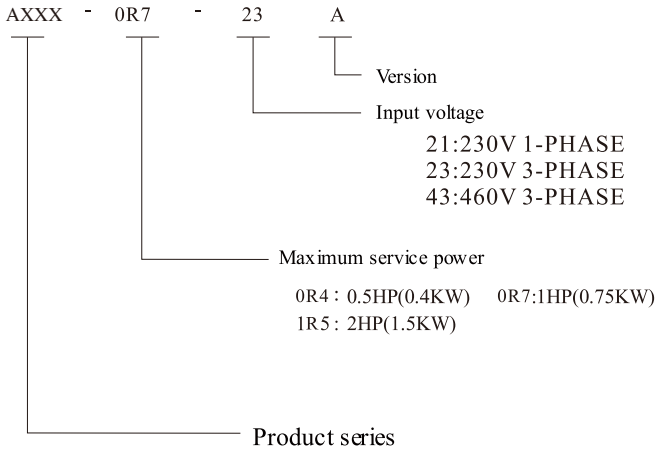

1.4 Operating Environment

The installation environment, which has direct impact on the functions and service life of the inverter, should meet the following conditions:

- Environmental temperature: Panel inner opening type: (-10~45°C/+14~113°F)

Locking wall-mounted type: (-10~40°C/+14~104°F).

- Prevent from rain and moisture.
- Avoid direct sunlight.
- Prevent from oil spray or corrosion by salt.
- Prevent from corrosive liquid or gas.
- Prevents from the invading of dust, cotton wool and fine metal scraps.
- Be far away from radioactive substance and combustible substance.
- Prevents from EMI (for example: EMI from sealing machines or power machine).
- Prevent from vibrations (punch). Please use shims to absorb librations if necessary.
- If several inverters are installed in a control board, please correctly lay out them for better heat emission. A ventilating fan should be equipped to keep the temperature below 45°C.

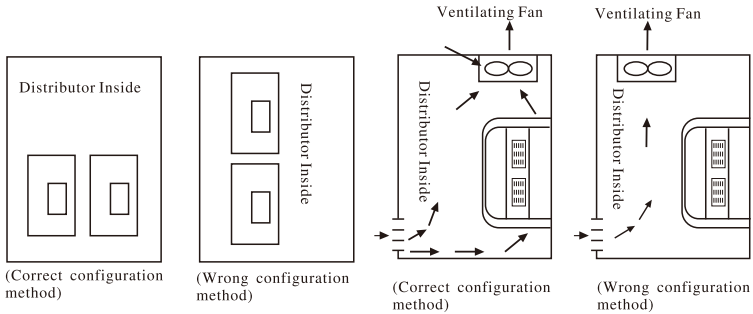

- The front surface of the inverter should face front for better heat emission.
- The installation space must comply with the following regulation: If the inverter is installed in the control board or the environment that is permitted, the upper dust cover can be taken down for better heat emission).

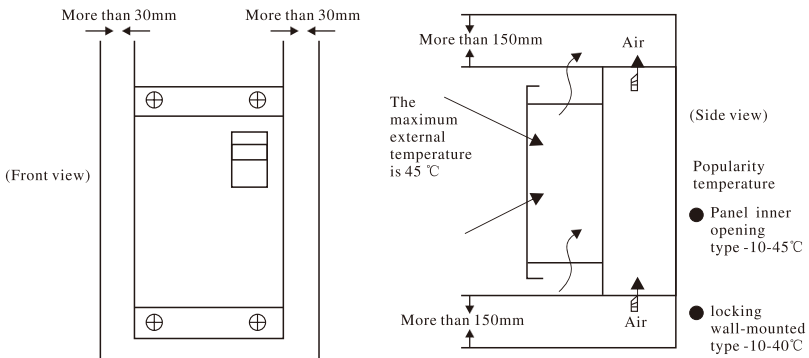

Chapter 2 Wiring Description

2.1 Basic wiring diagram

Diagram of single-phase inverter wiring:

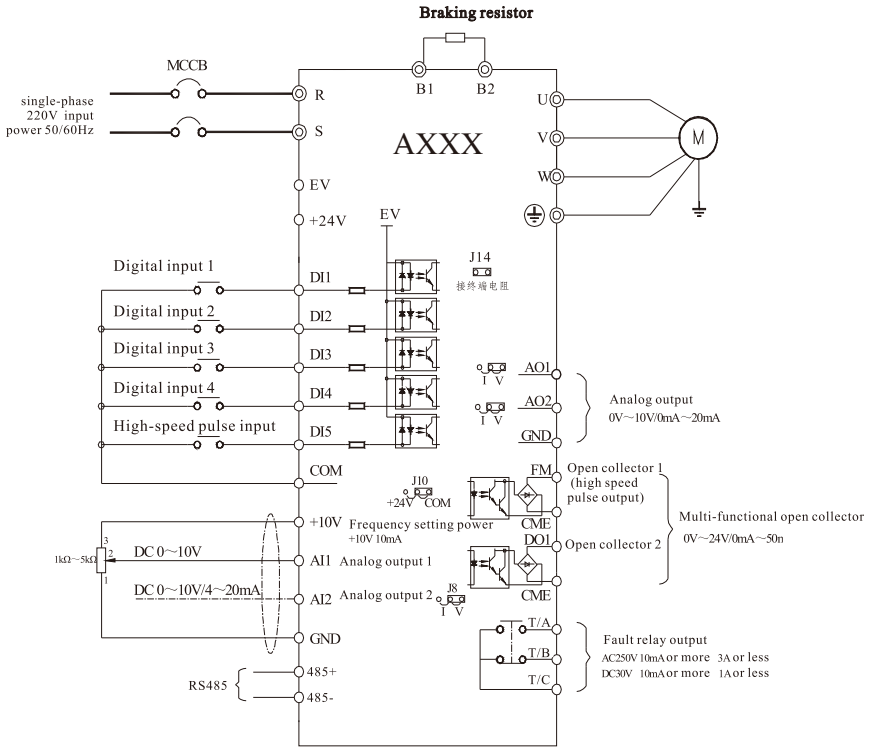

Single-phase inverter curve type wiring schematic

Note:

1. Terminal \odot means main circuit terminal, \circ means control circuit terminal
2. Braking resistor choice depends on the needs of users, detail see the braking resistor selection guide.
3. Signal and power lines must be separated, if the control cable and power cable crossed, should be 90 degrees cross if possible. Analog signal lines is best to select shielded twisted pair, the power cable selects the shielding of three core cable (the specification range is larger than common electric cable)

Diagram of three-phase inverter wiring:

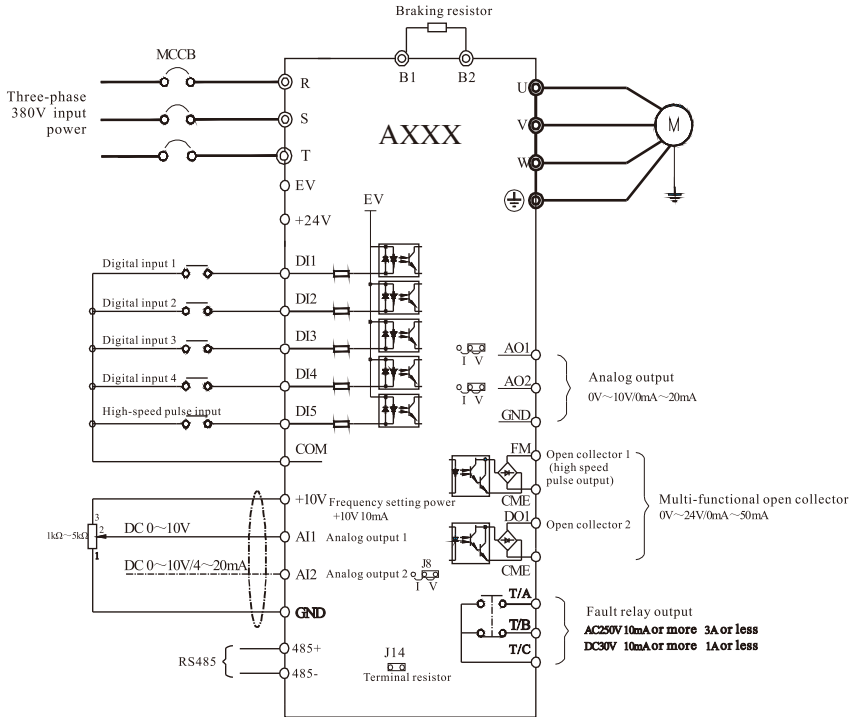

Three-phase inverter wiring schematic

Note:

1. Terminal \odot means main circuit terminal, \circ means control circuit terminal
2. Braking resistor according to the needs of users, detail see the braking resistor selection guide.

2.2 Main circuit terminal and wiring



Danger

1. Before wiring, please make sure that the power is completely switched off to avoid getting electrical shock and damaging the control device.
2. Wiring should be conducted by qualified professional to avoid electrical shock accidents or damages of the control device.
3. When wiring, have to connect to ground reliably to avoid electrical shock or fire.



Note

1. Confirm power input and the rated value of inverter are the same, to avoid inverter damaged!
2. confirm motor and inverter is matched, to avoid damage the motor or make inverter protected!
3. Impossible to connect power to U, V, W terminal, to avoid inverter damaged!
4. Impossible to connect brake resistance to DC BUS (+), (-) directly, to avoid fire!

Wiring of main circuit

It is the summary of wiring of main circuit input & output and the grounding line.

■ Wiring of main circuit input

Installation of breaker for wiring

A breaker for wiring (MCCB) suitable for the inverter power should be inserted between the power and input terminal.

- The MCCB capacity shall be 2 times of the rated current of inverter.
- The time characteristic of MCCB should take fully consideration of the time characteristic of inverter's overheating protection (150% of the rated output current: 1 minute).
- When MCCB is shared with more than two inverters or other equipment, please switch off (OFF) the power through a contactor in accordance with abnormal output connection showed in the figure below.

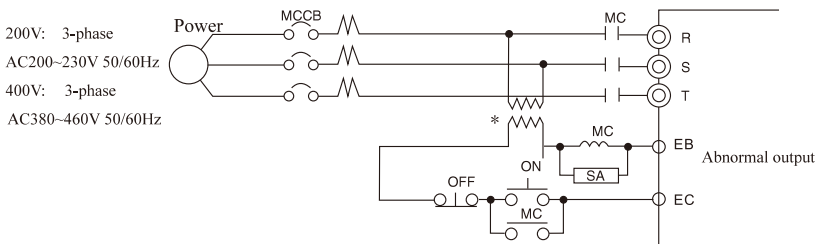

* For 400V class, please connect to the 400/200V transformer

Setup of breaker for wiring

Main circuit terminal marking instructions

Purpose	Terminal
Main circuit power input	R,S,T
Inverter output	U,V,W
Braking resistor wiring	B1,B2
Grounding	

Case:7.5W

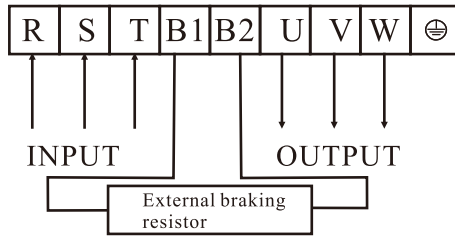

Control terminal marking instructions

GND	+10V	A11	A12	D11	D12	D13	D14	D15	COM				
	485+	485-	AO1	AO2	CME	COM	DO1	FM	+24V	EV	T/A	T/B	T/C

Control terminal function illustration

Type	Terminal mark	Terminal Name	Function instructions
Power	+10V-GND	External power supply +10V	The external power +10V, the maximum output current: 10mA,generally used for external potentiometer power,potentiometer resistance range:1k Ω ~5k Ω
	+24V-COM	External power supply +24V	The external power+24V,Generally using for inputting and outputting terminals working power & External sensor power maximum output power:200mA
	EV	External power input terminal	Default connecting with +24V,when using external voltage signal driveD11~D15, Evneed to connect wit external power,also unpin the connector EV and +24V.
Analog input	AI1-GND	Analog input terminals 1	1. Input voltage range:DC0V~10V 2. input impedance;22 k Ω
	AI2-GND	Analog input terminals 2	1.Input range:DC0~ +10V/4Ma~20Ma,control board J8 jumper selection 2 input impedance: input voltage,22 k Ω input current500 Ω
Digital input	D11	Digital input 1	1.Optocoupler isolation, Compatible bipolar input 2.Input impedance2.4 k Ω 3. voltage range when inputting electrical level: 9V~30V
	D12	Digital input 2	
	D13	Digital input 3	
	D14	Digital input 4	
	D15	High-speed pulse input terminal	addition to a D11~D14 function, can also be used as a high-speed pulse input, the maximum input frequency:100kHz
Analog output	AO1-GND	Digital output terminal1	Selected by the control board jumpers, output voltage range:0V~10V; output current range:0mA~20mA
	AO2-GND		
Digital output	DO1-CME	Digital output 1	optocoupler isolation bipolar open-collector outputs output voltage range:0V~24V output current range:0mA~50mA
	FM-COM	High pulse output	By the restrict of function codeP5-00" FM terminal output style choice, as the high speed pulse output, the highest frequency to 50KHz ;when used as open-collector output and same toDO1 function
Relay output	T/A-T/C	Normally open terminal	Contact driving ability:AC250V,3A,COS ϕ =0.4 DC 30V, 1A
	T/B-T/C	Normally closed terminal	

For inductively loaded occasion such as relay driven by the coil, please insert a bypass diode in accordance with the figure.

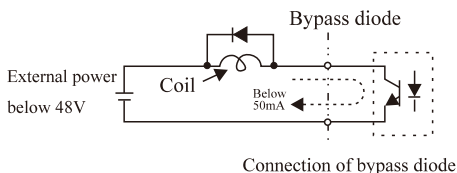

Please select a bypass diode with rated current larger than circuit current

Precautions for control circuit wiring

- The control circuit wiring should be separated from other power line or power supply line.
- The wiring of control circuit terminals RA, RC,EA,EB, EC (contact output) and terminals (FWD, REV, EF, RST, MS1,MS2,JOG,BX,MV+,MOC,MA+, Y1,Y2, YC,-15) and (CM, FIV, FIC, +15, MFI, 0) should be separated.
- In order to avoid fault caused by interference, please use the shielded twisted cable or shielded twisted pair cable. The treatment for cable end should be in accordance with the figure below; and the wiring distance should be less than 50m.
- Please connect the shielded network cable to the grounding terminal (E).
- Please do not contact shielding mesh cable to other signal lines and equipment shells; it should be wrapped with insulation tape.

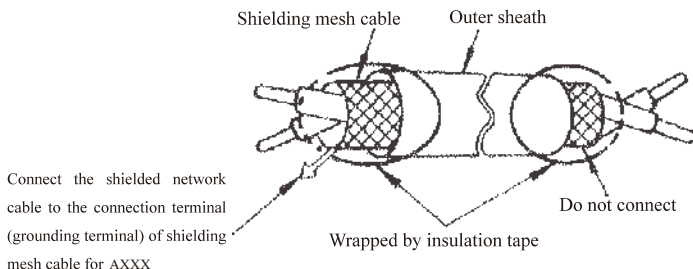

Wrapping end of shielded twisted pair cable

Chapter 3. Operation and display

3.1 Connection introduction of operation and display

You can modify the functional parameter, monitoring the working status, controlling the operation(start, stop) for the frequency transformer by the operation panel, the exterior and the function area is as below:

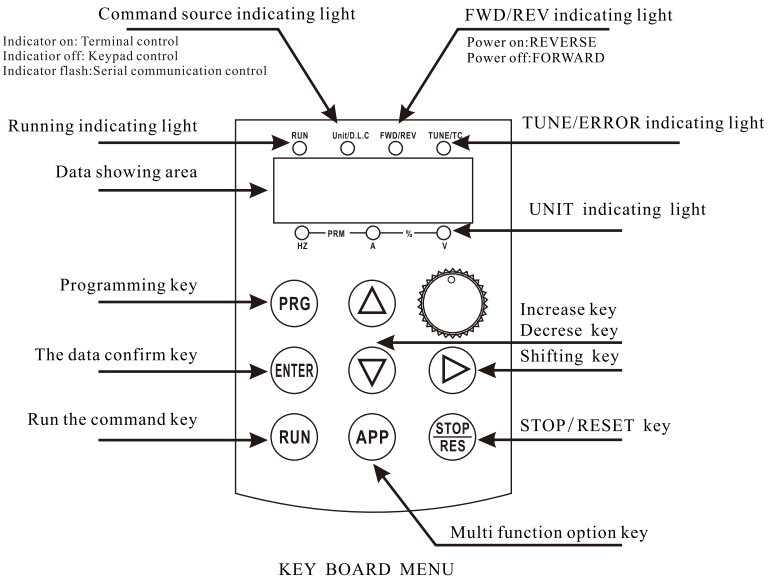

Keys Instruction

KEY	NAME	FUNCTIONS
PRG	PROGRAMMING	Enter or exit one level menu
ENTER	CONFIRMATION	Enter menu by level, set parameter confirmation
△	UP	Data or function code increasing
▽	DOWN	Data or function code decreasing
▷	SHIFT	Select display parameters cycling when off display port and running display port; select parameters placement when revision.
RUN	RUNNING	Used to run operation when keyboard is running
STOP/RES	STOP/RESET	Stop the operations when pressing this key; reset the operations when fault alarm. The property of this key is conditioned by function code P7-02
APP	MULTI-FUNCTIONS OPTIONS	According P7-01 to switch function options

LED instructions:

Indicator light	Light instructions
RUN	Running status indicating lighter: Power off indicates inverter is at stop; Power on indicates inverter is running;
TUNE/ERR	TUNE/TORQUE CONTROL/ERR indicating lighter: Power on indicates torque control, lighter slow flash indicates TUNE, lighter quick flash indicates ERROR
FWD/REV	Power off indicates FORWARD operation Power on indicates REVERSE operation
UNIT/D.L.C	Power off indicates KEY CONTROL Power on indicates TERMINAL CONTROL Lighter flash indicates serial communication operation
Hz	a unit of frequency UNIT:Hz
A	Current indicating lighter, Unit:A
V	Voltage indicating lighter: Unit:V
RPM	●—○—○—○ Both lighter of Hz and A are on is ROLLING SPEED ○—○—○—○ indicating lighter, UNIT:RPM
%	○—○—○—○ Both lighter of A and V are on is PERCENT UNIT:%

3.2 Explanation for the digital operation controller

The control panel of AXXX frequency tranformer is made by the 3-level structure setting manu:

The 3-level is as below: Function parameter group(1st level), Function code(2nd level), Function code setting(3rd level), operation flow is as below:

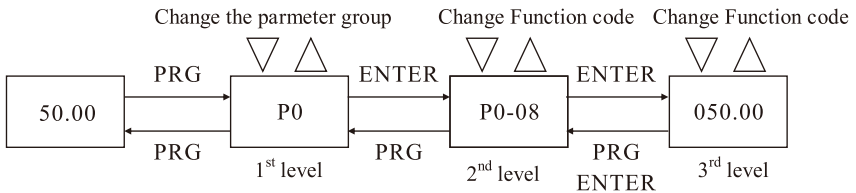

3-level operation flow chart

Remark: When operating at the 3rd level manu, you can choose the PRG or ENTER to return the 2nd level manu. The difference of the PRG and ENTER is: When you use ENTER, you can return the 2nd level manu after saving the current parameter; If you use PRG, you just return the 2nd level manu directly without saving the current parameter.

3.3 Check for the status parameter

When at the stop or operation status, you can use the "▶" to display the status for multiple parameters. You can decide the parameter display by the binary digi-choose bit of P7-03(operation parameter 1), P7-04(operation parameter 2), P7-05(stop parameter)

When at the stop status, you can choose whether displaying for sixteen parameters under stop status, there are: frequency setting, busbar voltage, Data input, Data output, analog input Voltage A11, analog input Voltage A12, analog input Voltage A13, actual counter, actual length, PLC operation step counter, offload speed display, PID setting, PULSE(input pulse frequency and the 3 remain parameter), you can display the chosen parameter by sequency of the button.

When at the operation status, five operation status parameters: operation frequency, setting frequency, busbar voltage, output voltage, output current are displaying(default). Other parameters' display could be chosen by P7-03, P7-04: output frequency, output torque, Data input, Data output, analog input Voltage A11, analog input Voltage A12, analog input Voltage A13, actual counter, actual length, linear speed, PID setting, PID feedback, you can display the chosen parameter by sequency of the button.

When the frequency power on after the interrupt, the parameter should be displayed as the setting before interruption.

3.4 Password setting

The frequency provides with the password protection, when the 16-00 is not 0, the exit function code/edit function is under protection, press "PRG" again, it should display "——", you must key in the correct password to enter the manu, or you can not access in.

If you want to cancel passwoed protection, just enter by key in the correct password, and set the 16-00 to 0.

Chapter4 Auto-tuning

4.1 Auto-tuning of motor parameter

To choose vector control mode, accurate nameplate parameters of the motor is needed to input before inverter works. inverter match standard motor parameter according to this nameplate parameter; Vector control mode relays on moto parameter strongly, so motor parameter must be accurate if user want to get better control performance

The steps of Motor parameter self-learning is as follows:

(1) To choose the command source (P0-02) as the command channel of the operating panel.

(2) To input the following 6 parameters according to the actual moto parameters:

P1-00:the type of motor selection P1-01: The motor rated power

P1-02: The motor rated voltage P1-03: the motor rated current

P1-04: The motor rated frequency P1-05: the motor rated speed

(3) Base on the motor load condition:

Dynamic learning with no load is the best way ,if no condition ,perhaps static learing is a choice.

1) Dynamic auto-tuning

If there is not any load, please set P1-37 to 2 and press enter key to confirm, then the keyboard will display:

TUNE

Press run key on the keyboard, The converter will drive to accelerate /decelerate the moto. Moto wil runson forward /reverse mode and the indicator light is ON . The process will last 2minuts. When the nomar information display,,self-learning is done.

After learning, the following moto parameters will be automatically calculated by inverter:

P1-06: Resistance of as ynchronous motor stator

P1-07: Resistance of asynchronous motor rotor

P1-08: Leakage reactance of asynchronous motor

P1-09: Mutual resistance of Asynchronous motor

P1-10: Unload current of Asynchronous motor

2) Static auto-tuning

If the load can't be cut off fully, please set P1- 37to 1/3, press enter key to confirm, then the keyboard displays

TUNE

Press the keyboard run key, Wait the motor parameter is recognized by inverter, the self-learning is done.

After auto-tuning, the following moto parameters will be calculated automatically by inverter:

P1-06: Resistance of asynchronous motor stator

P1-07: Resistance of asynchronous motor rotor

P1-08: Leakage reactance of asynchronous motor

Chapter 5 parameters specification

Group 0 basic function				
Function code	Name	Setting range	The smallest unit	Factory value
P0-00	G/P type display	G	1	1
P0-01	control mode option	0:The speed sensorless vector control (SVC) 2: V/F control	1	1

Option inverter operation mode, wherein the vector speed control and torque control through the DI terminal switch

0: The no-speed sensor vector control (SVC)

A inverter can drive a motor, used in higher requirements on the performance of motor control. Through the motor model dimension motor speed, fully compensated. Implementation of low frequency to high torque, high dynamic response. Can realize the direct control of the output torque, such as machine, drawing machine, reeling.

2: V/F control

It is suitable for to the load requirements not high, Such as belt machine, textile machinery, rapid start and stop of translation with variable torque preparation. Can drag torque constant or variable torque load, can be a motor to drive multiple, drag a high-speed motor and other special motor

P0-02	Command source selection	0	The selection panel command channel (LED go out)
		1	Terminal command channel (LED light)
		2	Serial-port communication command channel (LED flash)

Select the run command source about inverter

Inverter control commands include: start, stop, forward, inverse, pointing, fault reset etc.

0: Keyboard command channel

By the operation panel on the RUN, STOP/RESET, key to run, stop, reset function.

1: Terminal command channel:

By the multi-function input terminals FWD, REV, JOGF, JOGR etc..to run command and control.

2: Communication command channel

Run the command from the host computer through the communication method given.

P0-03	Main frequency source A selection	0:Digital setting (Preset frequency P0-08, UP/DOWN can be modified, Power off without memory) 1:Digital setting (Preset frequency P0-08, UP/DOWN can be modified, Power off with memory) 2:AI1 3:AI2 4: Remain 5:Pulse setting (DI5) 6:Multiple instruction 7, Simple PLC 8:PID 9:Communication is given 10:potentiometer	1	10
-------	-----------------------------------	---	---	----

P0-04	Auxiliary frequency source B selection	Same with the P0-03 (frequency command source A)	1	0
-------	--	--	---	---

Select A, B two groups of frequency source

0: function code P0-08 setting

Setting target frequency directly by setting function code P0-08., through UP, DOWN achieve frequency instruction fine tuning. Power-down without memory

1: function code P0-08 setting

Setting target frequency directly by setting function code P0-08., through UP, DOWN achieve frequency instruction fine tuning. Power-down with memory

2: AI1 setting; 3: AI2 setting

Setting frequency instruction by the analog. AI1 supports voltage input, AI2 supports voltage input or current input AI2 input voltage or current and setting frequency relationship can flexible set, reference function code P4-13~P4-22

5、Pulse-in pulse setting

By HDII frequency of terminal input pulse setting target frequency,support 0.00kHz~100.00kHz pulse input, reference function code P4-28~P4-31

6、Multi-speed instruction

By 4 digital DI input(function code P4-00~P4-04)can select one from 16 frequency instruction as target frequency, refer function code 12 groups

7、Simple PLC setting

Frequency instruction can be given directly by upper monitor through communication.

8、PID control setting

Select process PID control as the frequency source. Generally used for handicraft art close loop control, such as pressure closed-loop control, temperature closed-loop control. Detail reference function code10 group

9、Communication is given

Frequency instruction can be given directly by upper monitor through communication, Detail reference function code 13 group

10、Keyboard potentiometer setting

By rotating the panel potentiometer rotate to change the given frequency,can achieve 0.00Hz to maximum output frequency adjustment.P0-10Warning

WARNING: A, B channel can not choose the same frequency source

P0-05	Range of auxiliary frequency B for A and B operation	0:Compared with the maximum frequency 1:Compared with the main frequency source A	1	0
P0-06	Range of auxiliary frequency B for A and B operation	0%~150%	1%	100%
P0-07	Frequency source selection	The unit: The frequency of the source selection 0: The main frequency source A 1: The main result of operation (operation relations determined by decade) 2: The main frequency source A and B switching frequency source 3. The main frequency source A with main and auxiliary operation result switching 4. Auxiliary frequency source B with main and auxiliary operation result switching Decade:The main and auxiliary operation frequency source 0. The main+ auxiliary 1: The main- auxiliary 2: The two maximum values 3: The two minimum value	11	00

P0-08	Preset frequency	0.00Hz~The maximum frequency P0-10	0.00Hz	50.00Hz
P0-09	Rotation direction	0: Same direction 1: Reverse direction	1	0
P0-10	The maximum frequency	50.00Hz~ 500.00Hz	0.01Hz	50.00Hz

Maximum frequency as the reference of other variables , such as impulse input 、 Multi-velocity etc. For example, If analog input is 10V, convert rate is 100%, then output frequency equal 100%*P0-10

If P0-22=2, frequency resolution=0.01Hz, then P0-10 setting range is 50.00Hz~500.00Hz

Notes: The output frequency in all mode shall not exceed the maximum output frequency

P0-11	Source of frequency upper limit	0:P0-12 setting 1:A11 2:A12 3:reserved 4:pulse setting 5:communication setting	1	0
P0-12	UL frequency	FL frequency P0-14~UL frequency P0-10	0.01Hz	50.00Hz
P0-13	UL frequency offset	0.00Hz ~ Maximum frequency (P0-10)	0.01Hz	0.00Hz
P0-14	Frequency lower limit	0.00Hz ~ UL frequency (P0-12)	0.01Hz	0.00Hz
P0-15	Carrier frequency	0.5kHz ~ 16.0kHz	0.01kHz	Type determination
P0-16	Carrier frequency adjustment with temperature	0:no 1:yes	1	1
P0-17	Acceleration time 1	0.00s ~65000s	0.01s	Type determination
P0-18	Deceleration time 2	0.00s ~65000s 1	0.01s	Type determination

The acceleration time is that the frequency converter from zero frequency acceleration to the maximum r frequency (P0-10). The deceleration time is that the frequency converter from the speed reference frequency (P0-10) down to zero frequency. .AXX provide 4 selection about the acceleration/deceleration time(refer to P4 parameters) as the following table:

Selection terminal 2	Selection terminal 1	Acceleration/deceleration time group
invalid	invalid	Acceleration/deceleration time 1
invalid	valid	Acceleration/deceleration time 2
valid	invalid	Acceleration/deceleration time 3
valid	valid	Acceleration/deceleration time 4

If no acceleration/deceleration select function in terminal selection, that means invalid of terminal selection, please refer to Acceleration/deceleration time 1

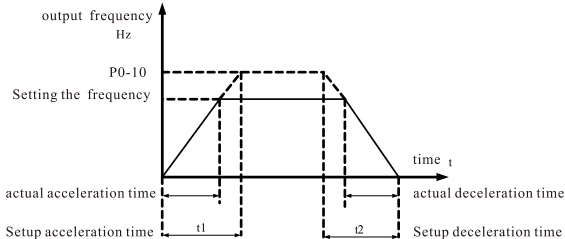

P0-19	Acceleration and deceleration time units	0: 1s 1:0.1 s 2:0.01s	1	1
P0-20	reserverd	/	/	/
P0-21	Biase frequency	0.00Hz ~ Maximum frequency(P0-10)	0.01Hz	0.00Hz
P0-22	Frequency reference resolution	1 :0.1 Hz 2: 0.01Hz If change this range ,please first setup maimum frequency 、 ULfrequency etc	1	2
P0-23	Retentive of digital setting frequency upon power failure	0: Not retentive 1: Retentive	1	0
P0-25	Acceleration/ Deceleration time base frequency	0: maximum frequency (P0-10) 1: setting frequency 2: 100Hz	1	0
P0-26	Base frequency for up/down modification during running	0: Running frequency 1: setting frequency	1	0
P0-27	Command source+ frequency source	0: No function 1: Digital setting 2: AI1 3: AI2 4: reserverd 5: Pulse reference (DI5) 6: Multi-reference 7: Simple PLC 8: PID reference 9: Serial comms. Units position: operating panel (keypad & display) + frequency reference setting channel Tens position: terminal I/O control + frequency reference setting channel Hundreds position: serial comms. + frequency reference setting channel	000	000
P0-28	Serial port comms. protoco	0:Moudbus	1	0
P1 electrical machine parameters				
P1-00	Type selection	0: The ordinary asynchronous motor 1: asynchronous frequency conversion motor	1	0
P1-01	Rated power	0.1Kw ~ 1000.0kW	0.1kW	Type determination
P1-02	Rated voltage	0V ~ 2000V	1V	Type determination
P1-03	Rated current	0.01A ~ 655.35A	0.01A	Type determination
P1-04	Rated frequency	0.00Hz ~ maximum frequency	0.01 Hz	Type determination
P1-05	Rated rotate speed	0rpm ~ 65535rpm	1rpm	Type determination
P1-06	Asynchronous motor stator resistance	0.001~ 65.535	0.001	Type determination
P1-07	Asynchronous motor rotor resistance	0.01~ 65.535	0.001	Type determination
P1 08	Asynchronous motor leakage	0 01 m H 655 35 m H (inverter power)	0 01 mH	Type determination

P1-09	Mutual inductive reactance	0.1 mH ~ 6553.5 mH	0.1 mH	Type determination
P1-10	No-load current	0.01A ~ P1-03	0.01	Type determination
P1-37	Tuning selection	0: No auto-tuning 1: Static auto-tuning 1 2: Dynamic auto-tuning 3: Static auto-tuning 2	1	0
P2 electrical machine vector control parameter				
P2-00	Velocity loop proportional gain 1	1 ~100	1	30
P2-01	Velocity loop integral time 1	0.01s ~ 10.00s	0.01s	0.50s
P2-02	Frequency switching 1	0.00 ~P2-05	0.01Hz	5.00Hz
P2-03	Velocity loop proportional gain 2	1 ~100	1	20
P2-04	Velocity loop integral time 2	0.01s ~ 10.00 s	0.01 s	1.00s
P2-05	Frequency switching 2	P2-02 ~Maximum frequency	0.01 Hz	10.00 Hz

Users can set up two groups of P1 Parameter to match low frequency or high frequency condition, there is a smooth transition between the two operation modes as the following figure:

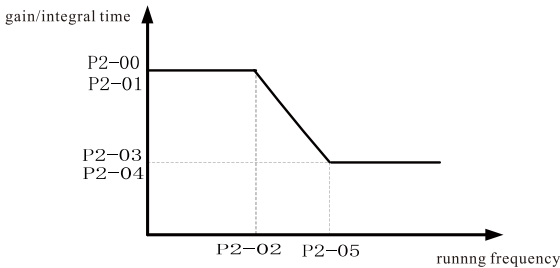

velocity loop parameter diagram

Velocity loop proportional gain (P2-00、 P2-03)

Please adjust these parameters according to the moto load. For heavy load, please increase proportional gain. For light load , please reduce proportional gain. When the velocity loop proportional gain is larger, velocity response is faster, but moto speed will be potentially unstable. When the velocity loop proportional gain is smaller, velocity reponse is slower and setting time will be longer.

Velocity loop integral time(P2-01、 P2-04)

The same to velocity loop proportional gain , when velocity loop intergral time is shorter, velocity response will be faster and moto speed will be potentially unstable. When velocity loop inegral time is longer, velocity response will be slower and setting time will be longer as the following figure:

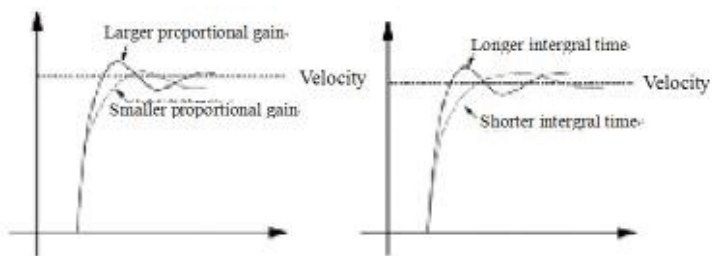

Velocity loop P1 parameter figure.

P2-06	Vector control slip gain	50% ~200%	1%	100%
P2-07	Velocity loop filter time constant	0.000s ~0.100s	0.001s	0.000s
P2-09	Torque limit source in speed control	0: P2-10 1: AI1 2: AI2 3: AI3 4: Pulse reference (DI5) 5: Serial comms. 6: Min. (AI1, AI2) 7: Max. (AI1, AI2)	0	0
P2-10	Digital setting of torque limit in speed control	0.0 % ~200.0%	0.1%	150.0%
P2-11	Torque limit source in speed control (regenerative)	0: P2-12 1: AI1 2: AI2 3: AI3 4: Pulse reference (DI5) 5: Serial comms. 6: Min. (AI1, AI2) 7: Max. (AI1, AI2)	0	0
P2-12	Digital setting of torque limit in speed control (regenerative)	0.0 % ~200.0%	0.1%	150.0%
P2-13	Excitation regulation proportional gain	0~60000	1	2000
P2-14	Excitation regulation intergral gain	0~60000	1	1300
P2-15	Torque regulation proportional gain	0~60000	1	2000
P2-16	Torque regulation intergral gain	0~60000	1	1300
P2-17	Velocity loop intergral property	bit: Integral separation 0:invalid 1:valid		0
P2-21	Max. torque coefficient of field weakening area	50% to 200%	0.1%	100%
P2-22	Regenerative power limit selection	0: Disabled 1: Enabled in the whole process 2: Enabled at constant speed 3: Enabled during deceleration	1	0
P2-23	Regenerative power limit	0. 0% to 200. 0%	0.1%	Model dependent

P3 controller parameter				
P3-00	V/F curve setting	0: straight V/F curve 1: multipoint V/F curve 2:square V/F curve 3:the power of 1.2 V/F curve 4:the power of 1.4 V/F curve 6:the power of 1.6 V/F curve 8:the power of 1.8 V/F curve	1	0
P3-01	Torque improvement	0.0% :(auto torque improve) 0.1% ~30.0%	0.1%	Type determination
P3-02	Torque Max frequency	0.00Hz ~ Maximum frequency	0.01	50 Hz

When V/F is running, to compensate for the voltage loss in motor stator, it need to compensate certain voltage value by artificially, set by P3-01(below diagram), the offset value is larger, but it should not exceed the rated voltage(10.0%).

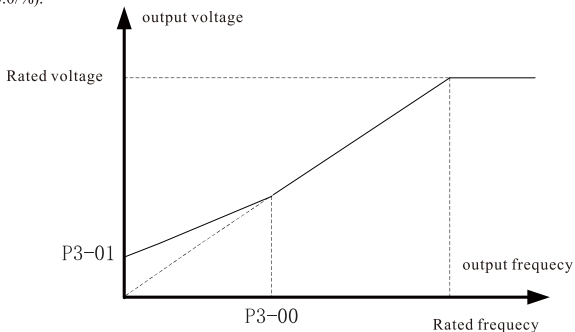

Torque improvement figure

If P3-02 is set to 1, frequency and voltage is determined by the above function code, please refer to the following figure. If the first point is 0.00 Hz, output voltage is the value corresponding to torque (P3-01 setting). The five point is rated frequency, so output voltage is the rated voltage. other voltages are made of five linear interpolation. Multi- V/F is used on the conditions that users have special requirements on output voltage, it also can settle the resonance phenomena.

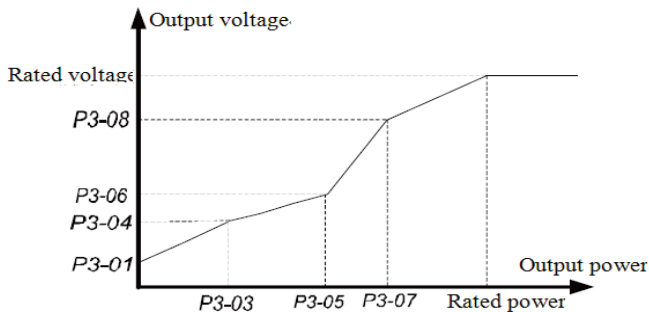

Multistage V/F curve figure:

P3-03	Multipoint VF frequency 1	0.00Hz ~P3-05	0.01 Hz	0.00 Hz
P3-04	Multipoint VF voltage 1	0.0% ~100.0%	0.1 %	0.0%

P3-05	Multipoint VF frequency 2	P3-03~P3-07	0.01 Hz	0.00 Hz
P3-06	Multipoint VF voltage 2	0.0%~100.0%	0.1 %	0.0%
P3-07	Multipoint VF frequency 3	P3-05 ~rated power(P1-04)	0.01 Hz	0.00 Hz
P3-08	Multipoint VF voltage 3	0.0% ~ 100.0%	0.1 %	0.0 %
P3-09	VF slip offset ratio	0.0% ~ 200.0%	0.1%	0.0 %
P3-10	VF overexcitation gain	0~200	1	64
P3-11	Oscillation suppression	0~100	1	Type determination
P3-13	Voltage source for V/F separation	0: Set by P3-14 1: AI1 2: AI2 3: AI3 4: Pulse reference (DI5) 5: Multi-reference 6: Simple PLC 7: PID reference 8: Serial comms. 100.0% corresponds to the rated motor voltage (P1-02, B2-02).	1	0
P3-14	Digital setting of voltage for V/F separation	0 V to rated motor voltage	1	0 V
P3-15	Voltage rise time of V/F separation	0.0s to 1000.0s	1	0.0s
P3-16	Voltage decline time of V/F separation	0.0s to 1000.0s	1	0.0s
P3-17	Stop mode selection for V/F separation	0: Frequency and voltage declining to 0 independently 1: Frequency declining after voltage declines to 0	1	0
P3-18	Current limit level	50% to 200%	1%	150%
P3-19	Current limit selection	0: Disabled 1: Enabled	1	1
P3-20	Current limit gain	0 to 100	1	20
P3-21	Compensation factor of speed multiplying current limit	50% to 200%	1	0
P3-22	Voltage limit	650 to 800 V	1	760V
P3-23	Voltage limit selection	0: Disabled 1: Enabled	1	1
P3-24	Frequency gain for voltage limit	0 to 100	1	30
P3-25	Voltage gain for voltage limit	0 to 100	1	30
P3-26	Frequency rise threshold during voltage limit	0 to 50 Hz	1	5HZ

P4-00	DI1 terminal function selection	0: no function		1
P4-01	DI2 terminal function selection	1:forward run	1	2
P4-02	DI3 terminal function selection	2.reverse run 3.trilinear operation controller 4: PJOG 5: RJOG 6.terminal up 7.terminal down 8.free parking 9.fault reset 10.Pause 11.input interfae for external fault(always open) 12.multi instruction terminal 1 13. multi instruction terminal 2 14.multi instruction terminal 3 15.multi instruction terminal 4 16.acceleration/decelaration selection terminal 1 17.acceleration/decelaration selection terminal 2 18.frequency source swich 19. up/down Set the reset(terminal, keypad) 20.Running command switch terminal 21.acceleration/deceleration prohibited 22. PID pause 23. PLC reset 24.swing frequency pause 25.counter input 26.counter reset 27.length counter input 28.length counter reset 29. torque control prohibited 30.PULSE Input(only for DI5) 31.reserved 32.DC braking		9

P4-03	D14 terminal function selection	33. input interfae for external fault(always close)	12
P4-04	D15 terminal function selection	34. frequency setting take effect terminal(don't set this terminal function, default valid)	13
P4-05	reseverd	if setting the terminal function, then when frequency modified,use the terminal valid controlling modify effect. If this terminal is valid, then PID active opposite 10-03 direction 36.external power down terminal 1 Controlled by keyboard, it can be used to stop . the function is same to stop key on the keyboard 37. control command swith terminal 2 Switch between terminal control mode and communication control mode, 38.PID integration pause terminal If valid ,PID integration pause pause ,but proportional regulator and differential regulator still work 39.terminal for switch between frequency sou _{rce} X and preset frequency .if valid preset frequency(p0-08) will replace frequency source X 40. terminal for switch between frequency sou _{rce} Y and preset frequency .if valid preset frequency(p0-08) will replace frequency source y 41.reserved 42.reserved 43PID parameter switch terminal 44.reserved 45.reserved 46.switch between velocity control and torque control 47.emergency STOP 48.external stop terminal 2 Any mode, this terminal can be used to stop according to deceleration time 4 49.deceleration DC braking 50.clear running time 51:Two-wire control/ Three-wire control 52:Reverse running prohibited 53-59: reserved	1

Multiple instruction declaration

K ₄	K ₃	K ₂	K ₁	Instruction setting	The corresponding parameter
OFF	OFF	OFF	OFF	Multiple instruction 0	12-00
OFF	OFF	OFF	ON	Multiple instruction 1	12-01
OFF	OFF	ON	OFF	Multiple instruction 2	12-02
OFF	OFF	ON	ON	Multiple instruction 3	12-03
OFF	ON	OFF	OFF	Multiple instruction 4	12-04
OFF	ON	OFF	ON	Multiple instruction 5	12-05
OFF	ON	ON	OFF	Multiple instruction 6	12-06
OFF	ON	ON	ON	Multiple instruction 7	12-07
ON	OFF	OFF	OFF	Multiple instruction 8	12-08
ON	OFF	OFF	ON	Multiple instruction 9	12-09
ON	OFF	ON	OFF	Multiple instruction 10	12-10
ON	OFF	ON	ON	Multiple instruction 11	12-11
ON	ON	OFF	OFF	Multiple instruction 12	12-12
ON	ON	OFF	ON	Multiple instruction 13	12-13
ON	ON	ON	OFF	Multiple instruction 14	12-14
ON	ON	ON	ON	Multiple instruction 15	12-15

4 multiple instruction terminals can be combined into 16 states corresponding to the setting value. As shown in the following table, multiple instruction is used not only for multiple speed but also for reference of PID source to meet the requirement of switching different given values.

When choosing the frequency source for multi-speed, "100%" of the function code 12-00~12-15, is corresponding to the maximum frequency of P0~P10.

When multiple instruction is the source of PID, "100%" of the function code 12-00~12-15 is the instrument full range.

Terminal 2	Terminal 1	acceleration /deceleration time option	The corresponding parameter
OFF	OFF	acceleration time 1	P0-17、P0-18
OFF	ON	acceleration time 2	P8-03、P8-04
ON	OFF	acceleration time 3	P8-05、P8-06
ON	ON	acceleration time 4	P8-07、P8-08

P4-10	DI filter time	0.000s~1.000s	0.001 s	0.010s
P4-11	Terminal command	0:two-line 1 1:two-line 2 2:tri-linear 1	1	0

		3.tri-linear 2		
--	--	----------------	--	--

0: two wire mode 1: this mode is usually used as the two line pattern. By the terminal DIx, DIy to determine the motor forward or reverse operation.

Function code set as follows:

terminal	Setting value	Function description
DIx	1	Forword run
DIy	2	Reverse run

DIx、DIy are the input terminals for DI1-DI5,HD11, level valid.

K1	K2	Running command
0	0	Stop
1	0	Forword
0	1	Reverse
1	1	Stop

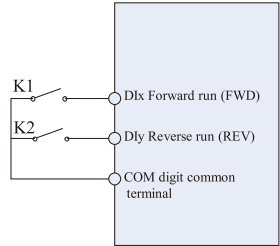

1: two wire mode 2: In this mode the DIx terminal function is for running enable and DIy terminal function is for the running direction(FWD/REV)

Function code set as follows:

terminal	Setting value	Functional description
DIx	1	Enable running
DIy	2	FWD/REV

DIx、DIy are the input terminals for DI1~DI15 digital part, level valid.

K1	K2	Running command
0	0	Stop
1	0	FWD
0	1	STOP
1	1	REV

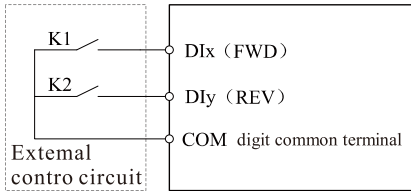

Two-line mode 2

2: three line type control mode: this mode is DIx enable terminal, direction is controlled by the DIx、DIY. Terminal function set as follows:

Terminal	Setting value	Functional description
Dlx	1	FWD
Dly	2	REV
Dln	3	Three line control operation1

- (1) When need run, must close terminal Dln firstly, by the pulse of Dln or Dly rising along the motor to realize forward or reverse of control
- (2) When need stop,must disconnect terminal Din signal to realize
- (3) Dlx、Dly、Dln is DI1~DI5 multi-function digital input terminals, Dlx、Dly is pulse effective, Dln is level effective.

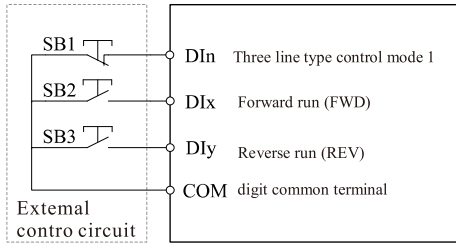

Three line type control mode 1

three line type control mode 1

(4)SB1: Stop button SB2: forward button SB3: reverse button.

3: three line type control mode 2: this mode the enable terminal is Dln, run the command given by the Dlx.

Function code set as follows

Terminal	Setting value	Functional description
Dlx	1	Running
Dly	2	FWD /REV
Dln	3	Three line control operation2

- (1) When need run, must close terminal Dln firstly, by the pulse of Dlx rising along the motor operation signal ,the state of Dly motor direction signal
- (2) When need stop,must disconnect terminal Dln signal to realize
- (3) Dlx、Dly、Dln is DI1~DI5 multi-function digital input terminals, Dlx、Dlx is pulse effective, Dln is level effective.

K	Run the command
0	Forward
1	Reverse

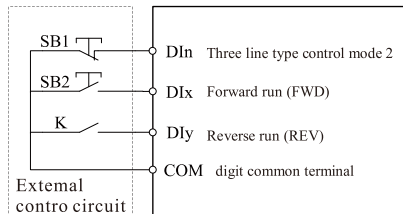

Three line type control mode 2

three line type control mode 2

(4)SB1: Stop button SB2: forward button-K: FWD and REV switching

P4-12	Terminal UP/DOWN per s change rate	0.001Hz~65.535Hz	0.01Hz	1.00Hz
-------	------------------------------------	------------------	--------	--------

Set the terminal UP/DOWN adjust setting frequency, speed of frequency change, namely the change frequency per second.

P4-13	AI1 minimum input	0.00V~P4-15	0.01V	0.00V
P4-14	Corresponding setting of AI curve 1 minimum input	-100.00%~100.0%	0.1%	0.0%
P4-15	AI1 maximum input	P4-13~10.00V	0.01V	10.00V
P4-16	Corresponding setting of AI curve 1 maximum input	-100.00%~100.0%	0.1%	100.0%
P4-17	AI1 input filter time	0.00s~10.00s	0.01s	0.10s

The function code is setting between the analog input voltage and the setting value relationship

When analog input voltage is greater or less than the set upper limit input (P4-15), or the lower limit (P4-13), please calculation with upper limit (P4-15) or the lower limit (P4-13)

The AI1 input filter time,used for setting software filtering time, when the field analog easily distracted please increase the filtering to make analog detection tends to be stable but the response speed of filtering time is greater for analog detection of slow, how to design .the need to balance based on the actual application.

In different applications, the corresponding simulation setting 100% nominal value has different meaning, please refer to the specific application of the following illustrations for two kinds of typical set of circumstances

The following illustrations is two typical setting:

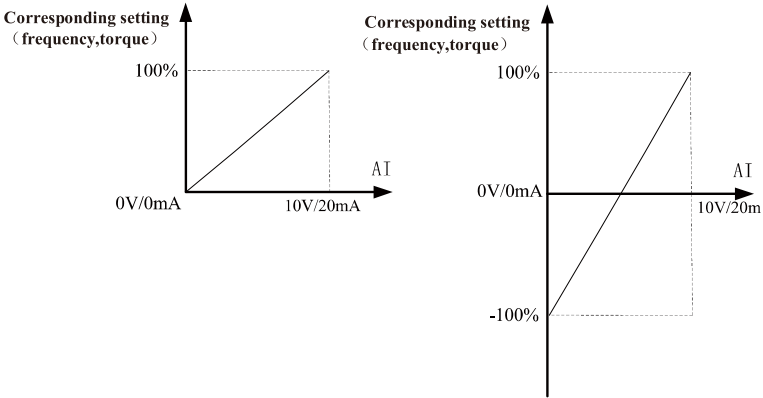

the corresponding of a given and setting

the corresponding of a given and setting

P4-18	AI2 minimum input	0.00V~P4-20	0.01V	0.00V
P4-19	Corresponding setting of AI curve 2 minimum input	-100.00%~100.0%	0.1%	0.0%

P4-20	AI2 maximum input	P4-18~10.00V	0.01V	10.00V
P4-21	Corresponding setting of AI curve 2 maximum input	-100.00%~100.0%	0.1%	100.0%
P4-22	AI2 input filter time	0.00s~10.00s	0.01s	0.10s
P4-23 ~ 4-27	Retain			
P4-28	Pulse minimum input	0.00kHz~P4--30	0.01kHz	0.00kHz
P4-29	Corresponding setting of pulse minimum input	-100.00%~100.0%	0.1%	0.0%
P4-30	Pulse maximum input	P4-18~100.00kHz	0.01kHz	50.00kHz
P4-31	Corresponding setting of pulse maximum input	-100.00%~100.0%	0.1%	100.0%
P4-32	Pulse input filter time	0.00s~10.00s	0.01s	0.10s
P4-33	AI set the curve options	The unit: All curve options 1 : Curve 1 (2 point, See P4-13~P4-16) 2: Curve 2 (2 point, See P4-18~P4-21) 3: Retain 4: Retain 5: Retain Decade: AI2 curve selection (1~5, ditto) Hundred: Retain	1	321
P4-34	Setting for AI less than minimum input	The unit: All below the minimum input options 0 :the minimum input corresponds to the setting 1: 0.0% Decade: AI2 below the minimum input selection (0~1, ditto) Hundred: retain		000
P4-35	DI1 Delay time	0.0s~3600.0s	0.1s	0.0s
P4-36	DI2 Delay time	0.0s~3600.0s	0.1s	0.0s
P4-37	DI3 Delay time	0.0s~3600.0s	0.1s	0.0s
P4-38	DI valid mode selection 1	0: High level 1 : Low level The unit: DI1 Decade: DI2 Hundred: DI3 Kilobit: DI4 Myriabit: DI5	1	0000
Group P5 The output terminal				
P5-00	FM the terminal output option	0: Pulse output (FMP) 1: Open collector output (FMR)	1	0
P5-01	FMR output function option	0: no-output 1: Inverter run 2: Fault output(fault stop) 3: Frequency level detect FDT arrive 4: Frequency arrive		

		5: zero-speed running (stop no-input) 6: Motor overload alarm 7: inverter overload alarm 8: Setting the counting pulse arrive 9: The specified count pulse arrive 10: Length arrive			
Function code	Name	Setting range	Minimum unit	Factory value	
P5-02	Relay function (R/A-R/B-R/C)	11: PLC the cycle is completed 12: Cumulative the running time of arrival	1	2	
P5-03	retain	13: The frequency limitation 14: Torque limitation 15: Ready for operation 16: AI1>AI2 17: The upper frequency limit reached 18: Lower frequency limit reached 19: Undervoltage state output 20: Communication settings 21: Complete orientation 22: Location close to 23: Zero speed operation 2 24: Power on time of arrival 25: the level of frequency detect FDT2 output 26: Frequency to the 1 output 27: Frequency to the 2 output 28: current to 1 output 29: current to 2 output 30: Time arrive output 31: The AI1 input exceeds the limit 32: Drop in 33: The running direction 34: Zero current detection 35: Module temperature is reached 36: The software flow output 37: The lower frequency of arrival (running independent) 38: The fault output 39: Motor over temperature alarm 40: The running time of arrival 41: Fault output	1	1	
P5-04	DO1 output option				
P5-05	retain				
P5-06	The FMP output option	0: Operating frequency	1	0	
P5-07	The A01 output option	1: Set the frequency	1	0	
P5-08	Retain	2: Output current 3: Output torque 4: Output power 5: The output voltage 6: pulse input(100.0% corresponding to 100.0.kHz) 7: AI1			

		8: AI2 9: Retain 10: Length 11: The count 12: Communication settings 13: Motor speed 14: Output current(100.0% corresponding to1000.0A) 15: Output voltage(100.0% corresponding to1000.0V) 16: Retain		
P5-09	Maximum FMP output frequency	0.01kHz~100.00kHz	0.01kHz	50.00kHz
P5-10	AoI offset coefficient	-100.0%~100.0%	0.1%	0.0%
P5-11	AOI gain	-10.00~10.00	0.01	1.00
P5-12	Retain			
P5-13	Retain			
P5-14	Retain			
P5-15	Retain			
P5-16	Retain			
P5-17	FM output delay time	0.0s~3600.0s	0.1s	0.0s
P5-18	RELAY1 output delay time	0.0s~3600.0s	0.1s	0.0s
P5-19	Retain			
P5-20	DO1 output delay time	0.0s~3600.0s	0.1s	0.0s
P5-21	Retain			
P5-22	DO valid mode selection	0-Positive logic: 1-Reverse logic The unit: FM Decade: RA/RB/RC Hundred: Retain Kilobit: DO1 Myriabit: Retain	11111	00000
Group P6 Start and stop control				
P6-00	Start mode	0: Directly start 1: Speed of revolution tracking restart 2: Pre excitation start (AC asynchronous motor) 3: SVC quick start	1	0
P6-01	Start frequency	0. 00Hz~10.00Hz	0.01	0.00
P6-02	Rotational speed tracking mode	0: Starting from the stop frequency 1: Start from power frequency 2: Starting from the maximum frequency	1	0
P6-03	Rotational speed tracking speed	1~100	1	20
P6-04	Startup frequency holding time	0.0s~100.0s	0.1s	0.0s

Start frequency is the initial frequency when the inverter starts. As the following diagram. Hold time of start frequency is the time the inverter keeps the start frequency until the frequency changes. Generally, start frequency is about 1Hz~2Hz, sometimes it will be larger in small power condition.

In small power condition ,user can build slip by setting start frequency. In large power condition or heavy load condition,extending hold time of start frequency will pre-excit motor ,reduce start current and improve torque. If the moto is working when start , users can lower rotate speed of the motor firstly, then improve it.

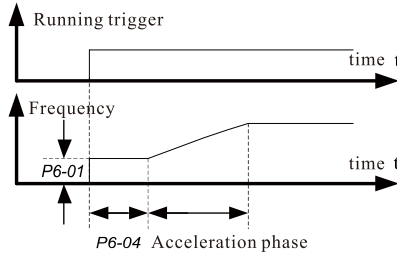

Start frequency figure

P6-05	Start DC braking/pre-excitation current	0%~100%	1%	0%
P6-06	Start DC braking/pre-excitation time	0.0s ~100.0s	0.1s	0.0s

Start DC braking/pre-excitation current is the current before the moto works.For this current(P6-05) 100% means the invert rated current. For the time(P6-06),P6-06 Set up the time of injection current , the result of contracting brake and pre-excitation will be got by injection current ,and start torque will be larger, surge current will be samller.

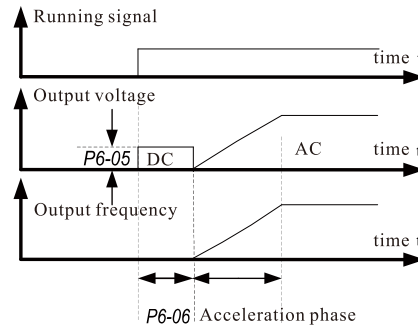

DC braking before starting figure

P6-07	Model of acceleration/deceleration	0: Inear acceleration/deceleration 1:S curve acceleration/deceleration A 2: S curve acceleration/deceleration B	1	0
-------	------------------------------------	---	---	---

P6-08	Proportion of s curve start time	0.0% ~ (100.0% -P6-09)	0.1%	30%
P6-09	Proportion of s curve stop time	0.0% ~ (100.0% -P6-08)	0.1%	30%

P6-08 and P6-09 define the time proportion of start time and stop time in the mode of S curve acceleration and deceleration A , the two function codes must meet the requirement : P6-08+P6-09 ≤ 100.0%.

t1 as the following figure is the parameter 6-08 defined, in this period output frequency slope increase gradually .
t2 as the following figure is the parameter 6-09 defined, in this period output frequency slope is fixed,it means linear acceleration .

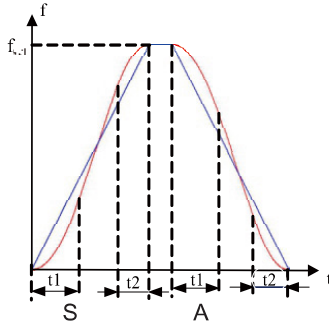

A diagram of S curve acceleration and deceleration

P6-10	Stop mode	0:deceleration shut down 1:free shut down	1	0
P6-11	Initial frequency of stop DC braking	0.00Hz ~ Maximum frequency	0.01Hz	0.00Hz
P6-12	Waiting time of stop DC braking	0.0 s ~100.0s	0.1 s	0.0s
P6-13	Stopping DC brake current	0% ~ 100%	1%	0%
P6-14	Stopping DC brake time	0.0s ~100.0 s	0.1s	0.0s

In the process of deceleration, when frequency is reduced to P6-11 ,wait some time(P6-12), DC is injected into moto to accelerate braking. The value of injection current is set by P6-13,100% means rated inverter current. The time injection current is set by P6-14, if the braking time is zero, there is no this process. The process is as the following figure.

P6-15	Braking efficiency	0% ~ 100%	1%	100%
P6-18	Speed tracking current size	30%~100%	1%	Models to determine
P6-21	Demagnetization time	0.00 ~ 5.00s	0.1s	0.0s

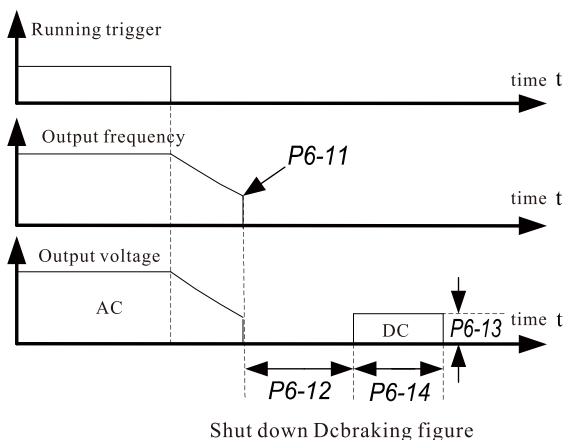

In the process of DC braking , keep retentivity on the rotor to prevent that rotor is unstable or crawling.

P7 Operation Panel and Display				
P7-00	Reserved			
P7-01	APP function	0:APP is invalid 1:switching between operation panel channel and remote command channel 2.switching between FWD add REV 3.normal inching turning 4.reverse inching turning	1	0
P7-02	STOP/RESE T function	0:STOP/RES is valid only under keyboard control 1:STOP/RES is always valid in any mode	1	1

P7-03	LED display parameter 1	<p>if need display the above parameter ,please Set up P7-03 with hexadecimal formate .("1" valid)</p>	1111	1P
P7-04	LED display parameter 2	<p>if need display the above parameter ,please Set up P7-04 with hexadecimal formate.("1" valid)</p>	1111	0
P7-05	LED display stop parameters		1111	33

		<p>if need display the above parameter ,please Set up P7-05 with hexadecimal formate.("1" valid)</p>		
P7-06	Load speed display coefficient	0.0001 ~6.5000	0.000 1	1.000
P7-07	Heatsink temperature of inverter module	0.0℃ ~100.0℃	0.1℃	
P7-08	Radiator temperature in the rectifier bridge	0.0℃ ~100.0℃	0.1℃	-
P7-09	Accumulative running time	0h ~65535h	1h	-
P7-10	Product ID			-
P7-11	Software verison	-		-
P7-12	Number of decimal places	0: zero decimal 1: one decimal		

	for load speed display	2: two decimal 3: three decimal		
P7-13	Accumulative power-on time	0 h ~ 6535 h	1 h	-
P7-14	Accumulative power consumption			-

P8 group auxiliary function				
P8-00	JOG running frequency	0.00Hz ~ Maximum frequency	0.01Hz	2.00Hz
P8-01	JOG acceleration time	0.0s ~6500.0 s	0.1 s	20.0 s
P8-02	JOG deceleration time	0.0s ~6500.0 s	0.1 s	20.0 s
P8-03	Acceleration time 2	0.0s ~6500.0 s	0.1 s	Type determination
P8-04	Deceleration time 2	0.0s ~6500.0 s	0.1 s	Type determination
P8-05	Acceleration time 3	0.0s ~6500.0 s	0.1 s	Type determination
P8-06	Deceleration time 3	0.0s ~6500.0 s	0.1 s	Type determination
P8-07	Acceleration time 4	0.0s ~6500.0 s	0.1 s	Type determination
P8-08	Deceleration time 4	0.0s ~6500.0 s	0.1 s	Type determination
P8-09	Jump frequency 1	0.00Hz ~maximum frequency	0.01Hz	0.00Hz
P8-10	Jump frequency 2	0.00Hz ~maximum frequency	0.01Hz	0.00Hz
P8-11	Frequency jump amplitude	0.00Hz ~maximum frequency	0.01Hz	0.00Hz
P8-12	Forward/Reverse rotation dead-zone time	0.0s ~3000.0 s	0.1 s	0.0 s
P8-13	REV Control	0:REV allowable 1:REV forbidden	1	0
P8-14	Running mode when set frequency lower than frequency lower limit	0: Run at frequency lower limit 1: Stop 2: Run at zero speed	1	0
P8-15	Droop control	0.00Hz ~10.00 Hz	0.01Hz	0.00Hz
P8-16	Accumulative power-on time threshold	0h ~65000h	1 h	0h
P8-17	Accumulative running time threshold	0h ~65000h	1h	65000h

P8-18	Starting protection option	0 :no protection 1:protection	1	0
P8-19	Frequency detect (FDT 1)	0.00 Hz ~ maximum frequency	0.01Hz	50.00Hz
P8-20	Frequency detection hysteresis	0.00%~100.0%(FDT level)	0.1%	5.0%

FDT function : When the output frequency exceed the value of FDT ,DO signal instruct FDT output is valid and DO signal instruct FDT output is invalid till the difference between output frequency and FDT exceed lagged value.
 $FDT \text{ lagged amplitude} = FDT \text{ lagged value} * FDT \text{ detect value}$

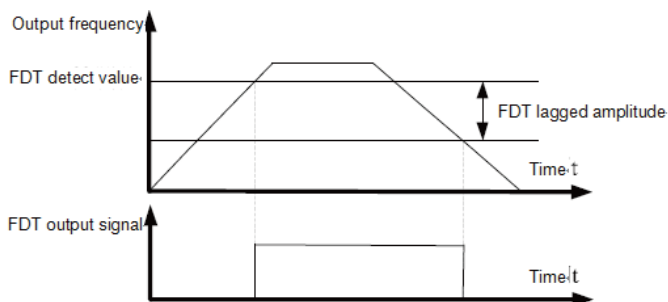

FDT signal figure

P8-21	Detection range of frequency reached	0.0% ~ 100.0% (maximum frequency)	0.1 %	0.0%
P8-22	Jump frequency during acceleration/deceleration	0:invalid 1:valid	1	0
P8-23	Action if working time accumulated arrive to limit	0:continue 1:Fault display	1	0
P8-24	Action if power-on time accumulated arrive to limit	0:continue 1:Fault display	1	0
P8-25	Frequency switchover point between acceleration time 1 and acceleration time 2	0.00Hz ~Maximum frequency	0.01Hz	0.00Hz
P8-26	Frequency switchover point between deceleration time 1 and deceleration time 2 0.00 to maximum	0.00Hz ~ Maximum frequency	0.01Hz	0.00Hz

The function explain that how to select acceleration/deceleration time automatically unusing DI terminal when the inverter is working.

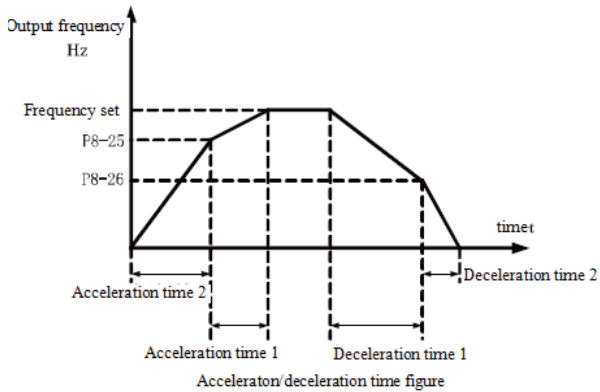

As the following figure , in the process of acceleration , if operation frequency is smaller than P8-25, then acceleration time 2 will be selected ,otherwise , acceleration time 1 will be selected.
 In the process of deceleration , if operation frequency is bigger than P8-26, then deceleration time 1 will be selected ,otherwise , deceleration time 2 will be selected.

P8-27	Terminal JOG preferred	0:invalid 1:valid	1	0
P8-28	Frequency detect value (FDT2)	0.00Hz ~ maximum frequency	0.01Hz	50.00Hz
P8-29	Frequency detect lagged value (FDT2)	0.0% ~ 100.0%(FDT2 level)	0.1%	5.0%
P8-30	Any frequency reaching detection value 1	0.00Hz ~ maximum frequency	0.01Hz	50.00Hz
P8-31	Any frequency reaching detection amplitude 1	0.0% ~ 100.0%(maximum frequency)	0.1%	0.0%
P8-32	Any frequency reaching detection value 2	0.00Hz ~ maximum frequency	0.01Hz	50.00Hz
P8-33	Any frequency reaching detection amplitude 2	0.0% ~ 100.0%(maximum frequency)	0.1%	0.0%

If inverter is working in the range of (P8-30+-P831) or (P8-32 +-P8-33),DO will output ON ,otherwise OFF.

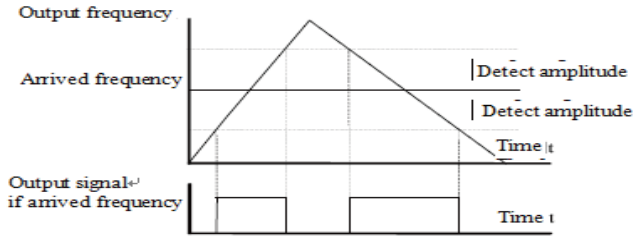

The function of arrived frequency detect figure

P8-34	Zero current detect	0.00%~300.0% 100% means rated current	0.1%	5.0%
P8-35	Zero current detect delay time	0.01 s ~600.0s	0.01 s	0.10 s
P8-36	Output overcurrent threshold	0.0%(no detect) 0.1%~300.0%(rated current)	0.1%	200.0%
P8-37	Output overcurrent detection delay time	0.00s ~600.00 s	0.01s	0.00s
P8-38	Any current reaching 1	0.0%~300.0%(rated current)	0.1%	100.0%
P8-39	Any current reaching 1 amplitude	0.0%~300.0%(rated current)	0.1%	0.0%
P8-40	Any current reaching 2	0.0%~300.0%(rated current)	0.1%	100.0%
P8-41	Any current reaching 2 amplitude	0.0%~300.0%(rated current)	0.1%	0.0%

If inverter is working in the range of (P8-38+-P8-39) or (P8-40 +-P8-41),DO will output ON,otherwise OFF.

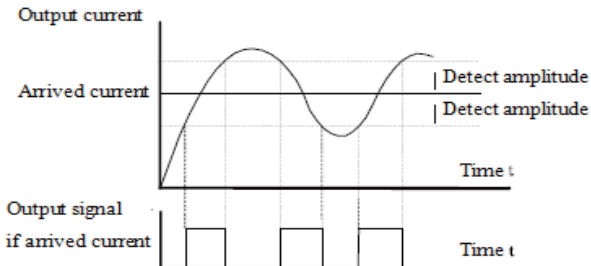

The function of arrived frequency and arrived current figure

P8-42	Option for timing function	0:invalid 1:valid	1	0
P8-43	Option for timing function mode	0:P8 -44(analog input) 1:A11 2:A12 3:A13	1	0

		analog input corresponding P8-44		
P8-44	Timing duration	0.0 min ~6500.0 min	0.1 min	0.0 min
P8-45	Ail input voltage lower limit	0.00V ~ P8-46	0.01V	3.10V
P8-46	Ail input voltage upper limit	P8-45~10.00V	0.01V	6.8V
P8-47	Module temperature threshold	0 °C ~ 100 °C	1°C	75°C
P8-48	Radiator fan control	0:radiator fan working under motro work 1:radiator fan working under power on	1	0
P8-49	Aakeup frequency	Sleeping frequency(P8-51) ~maximum frequency (P0-10)	0.01Hz	0.00Hz
P8-50	Aakeup delay time	0.0s ~ 6500.0 s	0.1 s	0.0s
P8-51	Ormant frequency	0.0 min ~ arousal frequency(P8-49)	0.01Hz	0.00Hz
P8-52	Ormant delay time	0.0s ~6500.0 s	0.1 s	0.0s
P8-53	Setting arrived time for this time	0.0min ~6500.0 min	0.1min	0.0min
P8-54	The output power calibration coefficient	0.00% ~200.0%	0.1%	100.0%

P9 group fault and protection				
P9-00	Motor overload protection selection	0: forbidden 1:allowable	1	1
P9-01	Motor overload protection gain	0.20 ~ 10.00	0.01	1.00
P9-02	Motor overload warning coefficient	50%~100 %	1%	80%

If P9-00 =0, software overload protection will be closed , so there is a risk that moto may be damaged ,strongly recommended to add a thermorelay to protect the motor.

If P9-00=1,software overload protection will be open , overload status can be judged by inverter inverting time curve.

The default inverting time curve : if 220%rated current is kept 1 minutes or if 150% rated current is kept 60 minutes there will be overload warning. Actual requirement can be meet by adjusting P9-01 code.

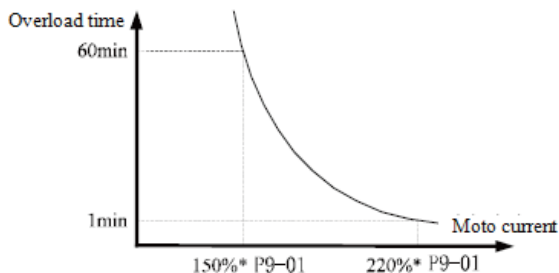

Moto overload curve

P9-02 is used to input a warning singla to control system by DO channe. The value is larger ,then waring magin time will be shorter.

P9-03	Overvoltage stall gain	0~100	1	30
P9-04	Overvoltage stall protective voltage	650 to 800 V	1	760V

P9-07	Power on to choose from the short circuit protection	bits:Power on to choose from the short circuit protection 0:no action 1:action ten:Before running of short circuit protection option 0:no action 1:action	1	01
P9-08	Braking unit applied voltage	650 to 800 V	1V	770V
P9-09	Fault auto reset times	0~20	1	0
P9-10	Action of DO in the period of fault auto reset	0:no action 1:action	1	0
P9-11	Interval time of fault auto reset	0.1s~100.0s	0.1s	1.0s
P9-12	Input phase loss protection	bits:Input the lack of protection option ten:Contactor and protection option 0:forbidden 1:allowable	1	1
P9-13	Output phase loss protection	bits:The output phase protection option ten:Before running the output phase protection option 0:forbidden 1:allowable	1	1
P9-14	First fault type	0: no fault	-	-
P9-15	Second fault type	1:overheat 1(OH1)	-	-
P9-16	Third time(last time) fault type	2:overcurrent accelerated(OCA) 3:overcurrent decelerated(OCD) 4:overcurrent normal(OCN) 5:overvoltage accelerated(OUA) 6:overvoltage accelerated(OUD) 7:overvoltage normal (OUN) 8:overload for buffer resistance(UU) 9.loss voltage (LU) 10.overload for inverter (OL2) 11.overload for moto(OL1) 12.reserved 13.reserved 14.writer/read parameter abnormally (ED) 15.external fault(EF) 16.communication fault(CE) 17.relay fault (RL) 18.current check fault (CC) 19.motor tuning fault (ER) 20.overtime fault (OT)	-	-

			21.fault defined by user 1(U1) 22.inverter hardware fault (EH) 23.short to ground fault (GF) 24.difference of velocity(DEV) larger(DEV) 25.overspeed fault (OS) 26.overheat for motor(OH2) 27. loss of PID (PD) 28.fault defined by user 2(U2) 29.power-on time to upperlimit(UT) 30.load loss(LL) 31:Rapid current- limiting timeout (LC) 32~36:reserve 37:The initial position error (INE) 38:The master-slave control from motor fault (MS)		
P9-17	Third time (last time)fault	frequency	-	-	-
P9-18	Third time (last time)fault	current	-	-	-
P9-19	Third time (last time)fault	busbar voltage	-	-	-
P9-20	Third time (last time)fault	status of input tetminal	-	-	-
P9-21	Third time (last time)fault	status of input tetminal	-	-	-
P9-22	Third time (last time)fault	status of inverter	-	-	-
P9-23	Third time (last time)fault	time from power on	-	-	-
P9-24	Third time (last time)fault	time from work	-	-	-
P9-25	reserved		-	-	-
P9-26	reserved		-	-	-
P9-27	Second fault	frequency	-	-	-
P9-28	Second fault	current	-	-	-
P9-29	Second fault	busbar voltage	-	-	-
P9-30	Second fault	status of input tetminal	-	-	-
P9-31	Second fault	status of input tetminal	-	-	-
P9-32	Second fault	status of inverter	-	-	-
P9-33	Second fault	time from power on	-	-	-
P9-34	Second fault	time from work	-	-	-

P9-35	Reserved	-	-	-
P9-36	Reserved	-	-	-
P9-37	First fault frequency	-	-	-
P9-38	First fault current	-	-	-
P9-39	First fault busbar voltage	-	-	-
P9-40	First fault status of input terminal	-	-	-
P9-41	First fault status of input terminal	-	-	-
P9-42	First fault status of inverter	-	-	-
P9-43	First fault time from power on	-	-	-
P9-44	First fault time from work	-	-	-
P9-45	reserved	-	-	-
P9-46	reserved	-	-	-
P9-47	Fault protection action selection 1	Unit :OL1 0:free parking 1:stop following setting 2.continue to run Decade:reserved Hundred:reserved Kilobit:EF Myriabit :CE	11111	00000
P9-48	Fault protection action selection 2	Unit: reserved 0:free parking Decade:ED 0:free parking 1:stop following setting Hundred :reserved Kilobit :OH2 Myriabit:OT	11111	00000
P9-49	Fault protection action selection 3	Unit :U1 0:free parking 1:stop following setting 2.continue to run Decade :U2 0:free parking 1:stop following setting 2.continue to run Hundred:UT 0:free parking 1:stop following setting 2.continue to run Kilobit:LL 0:free parking	11111	00000

		1.decelerate to stop 2.decelerate to 7% rated frequency,and return to normal frequency if LL is solved Myriabit :PID 0:free parking 1:stop follwing setting 2.continue to run		
P9-50	Fault protection action selection 2	Unit:DEV 0:free parking 1:stop follwing setting 2.continue to run Decade:OS Hundred:reserved	11111	00000
P9-51	reserved	-	-	-
P9-52	reserved	-	-	-
P9-53	reserved	-	-	-
P9-54	Frequency selection for continuing to run upon fault	0: Current running frequency 1: Set frequency 2: Frequency upper limit 3: Frequency lower limit 4: Backup frequency upon abnormality	1	0
P9-55	Backup frequency upon abnormality	60.0%~100.0%(current frequency)	0.1%	100.0%
P9-57	reserved	-	-	-
P9-58	reserved	-	-	-
P9-59	Action selection at instantaneous power failure	0:invalid 1:deceleration 2:decelerate to stop	1	0
P9-60	Action pause judging voltage at instantaneous power failure	60.0%~100.0%(standard busbar voltage)	0.1%	80.0%
P9-61	Voltage rally judging time at instantaneous power failure	0.00s~100.00s	0.01s	0.50s
P9-62	Threshold of power dip ride-through function enabled	60% to 85% (standard bus voltage)	0.1%	80.0%
P9-63	Protection upon load becoming 0	0:invalid 1:valid	1	0
P9-64	Detection level of load becoming 0	0.0~100.0%	0.1	10.0%
P9-65	Detection time of load becoming 0	0.0~60.0 s	0.1s	1.0s
P9-71	Power dip ride-through gain K_D	0 to 100	1	40
P9-72	Power dip ride-through integral coefficient	0 to 100	1	30
P9-73	Deceleration time of power dip ride-through	0.0s to 300.0s	0.1s	20.0s

PID system is a regulator which consists of proportion(P), integral (I), differential (D). It is suitable to process control for flow, pressure and temperature.

Proportion control(P)

To Control proportion of deviation

Integral control(I)

To Control proportion of intergral deviation,it can remove steady state error

Control differential(D)

To control proportion of differential deviation, it can forecast the deviation trend, answer the tremendous changes, improve the dynamic performance, but perhaps it introduce and amplify noise. please use it with caution.

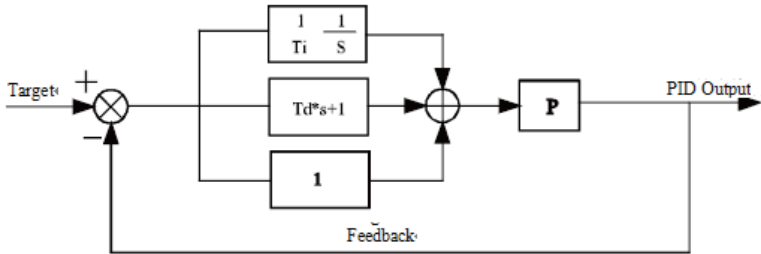

PID Control figure

10-00	PID source	0: function code(10-01) 1: AI1 2: AI2 3: reserved 4: PULSE(DI5) 5: communication 6: multispeed instruction	1	0
10-01	PID value	0.0% ~ 100.0%	0.1%	50.0%

If user want to use default value, keyboard is used to set PID. PID value is relative value, 100% means full scale feedback signal. system always calculate relative value (0.0%~100.0%).

Notes: If PID output is selected (for example, P0-03/P0-04 is set to 8), PID process control will be active.

10-02	PID feedback source	0:A11 1:A12 2:reserved 3:A11-AI2 4:Pulse-DI5 5:communication 6:A11+A12 7:MAX(A11 , A12) 8:MIN(A11 , A12)	1	0
10-03	PID direction	0:positive 1:negative	1	0
10-04	PID feedback range	0~65535	1	1000
10-05	Proportion gain P1	0.0~100.0	0.1	20.0
10-06	Integral time I1	0.01s ~ 10.00s	0.01s	2.00s
10-07	Differential time D1	0.000s ~10.000s	0.001s	0.000s
10-08	Cut-off frequency of PID reverse rotation	0.00 ~ maximum frequency	0.01 Hz	2.00Hz
10-09	PID diviation limit	0.00% ~100.0%	0.1%	0.0%

If the difference between PID instnction and PID feedback is less than the value by this function code setting, PID will stop regulating and keep PID output stable.

PID diviation limit VS output frequency as the following figure:

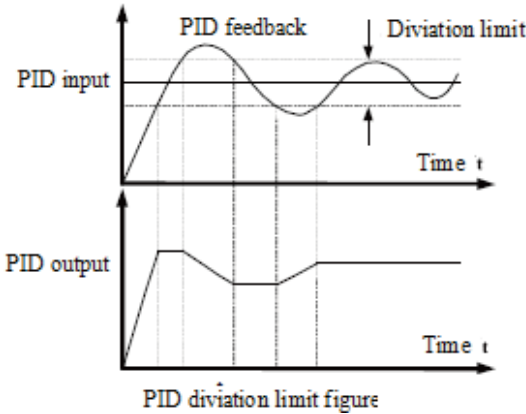

Function code	Name	Setting range	Unit	Default value
10-10	PID differential amplitude limit	0.00% ~ 100.00%	0.01%	0.10%
10-11	PID setting change time	0.00~650.0	0.01s	0.00 s
10-12	PID feedback filter tiime	0.00 ~ 60.00	0.01s	0.00s
10-13	PI output filter time	0.00 ~ 60.00	0.01s	0.00s
10-14	reserved	-	-	-

10-15	Proportion gain P2	0.0~100.0	0.1	20.0
10-16	Integral time I2	0.01s~10.00s	0.01s	2.00s
10-17	Differential time D2	0.000s~10.000s	0.001 s	0.000s
10-18	PID parameter switchover condition	0: No switchover 1: Switchover via DI 2: Automatic switchover based on deviation	1	0
10-19	PID parameter switch deviation 1		0.1 %	20.0%
10-20	PID parameter switch deviation 2		0.1%	80.0%

2 group separated PID control parameter can be set to 3 functions (not switch、DI terminal、auto switch), when auto switch function is selected, the absolute value of the difference between input and feedback is less than 10-19, the PID control parameter group 1 will be active; the absolute value of the difference between input and feedback is less than 10-20, the PID control parameter group 2 will be active. the absolute value of the difference between input and feedback is between 10-19 and 10-20, PID control parameter is linear interpolation values of the two groups.

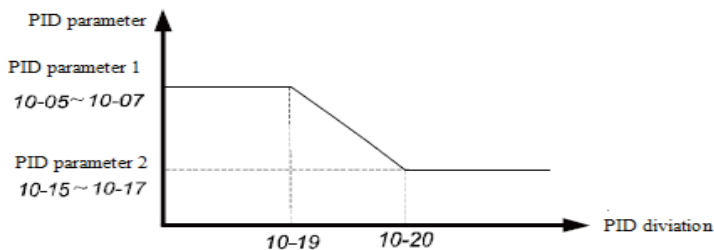

PID parameter auto switching figure

10-21	PID initial value	0.00%~ 100.0%	0.1 %	0.0%
10-22	PID initial value holding time	0.00 ~ 650.0%	0.01 s	0.00s

PID working frequency accelerate or decelerate to the pre-set value and keep the status till the saving time run out, then works at the set condition.

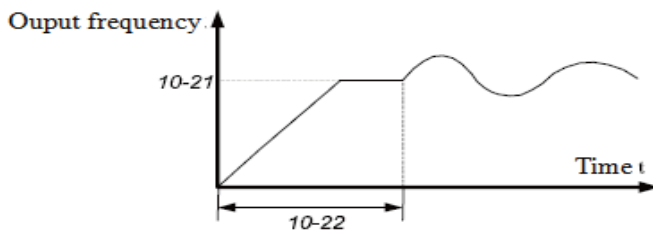

PID pre-set Output figure

10-23	Maximum deviation between two PID outputs in forward direction	0.0%~ 100.00%	0.01 %	1.00%
-------	--	---------------	--------	-------

10-24	Maximum deviation between two PID outputs in reverse direction	0.0% ~ 100.00%	0.01%	1.00%
10-25	PID intergral properties	Unit: intergral 0:invalid 1:valid Decade:output ot limit,if0 continue to intergral 1: stop intergral	11	00
10-26	Calculte action when stopping	0: not calculate when stopping 1:calculate when stopping	1%	0
10-27	Detection time of PID feedback loss	0.0 s ~ 20.0s	0.1 s	1.0s
10-28	Detection value of PID feedback loss	0.0% : not judge whether feedback loss 0.1% ~ 100.0	0.1	20.0%

Group 11 swing frequency, setting length and counter				
11-00	Swing frequency cycle	0:relative to center frequency 1:relative to maximum frequency	1	0
11-01	Swing frequency amplitude	0.0%~100.0%	0.1%	0.0%
11-02	Jump frequency amplitude	0.0%~50.0%	0.1%	0.0%
11-03	Swing frequency period	0.1%~3000.0s	0.1s	10.0s
11-04	Triangular wave rising time coefficient	0.1%~100.0%	0.1%	50.0%
11-05	setting length	0m ~ 65535m	0m	1000m
11-06	Actual length	0m ~ 65535m	0m	0m
11-07	Number of pulses per meter	0.1 ~6553.5	0.1	100.0

The above function code is used to set length.

Length information is collected by multifunction ,actual length(11-06)=the quantity of sample pulse /pulse quantity per meter(11-07).If actual length is larger than actual length(11-05),multifunction digital DO will output “length arrived” ON signal.

In the process of setting length , length reset can be operated by multifunction DI terminal,please refer to P4-00 ~P4-09.

Input terminal must be set to “length counter input” in the application. If pulse frequency is larger,D15 terminal must be needed.

11-08	Set count value	1~65535	1	1000
11-09	Designated count value	1~65535	1	1000

The conter value is gathred by multifunction input terminal. In the application input terminal must be set to “counter input”, if pulse frequency is larger ,D15 terminal must be needed.

If the counter value is equal to setting counter value (11-08), DO output “setting value arrived “ ON signal,then the counter will stop.

If the counter value is equal to setting counter value (11-09), DO output “setting value arrived “ ON signal,then the counter will continue to count till the setting counter value is arrived.

Setting value 11-09 should be less than setting value 11-08 as the following figure.

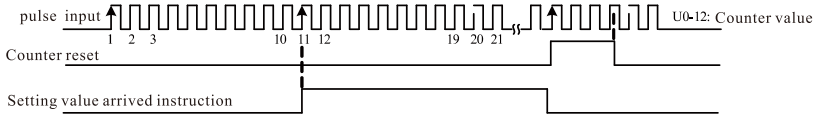

Counter value setting figure

Group 12 multi-instruction 、 Simple PLC				
12-00	Multi-instruction 0	-100.0% ~100.0% (100% means maximum output frequency p0-10)	0.1%	0.0%
12-01	Multi-instruction 1	-100.0% ~100.0%	0.1%	0.0%
12-02	Multi-instruction 2	-100.0% ~100.0%	0.1%	0.0%
12-03	Multi-instruction 3	-100.0% ~100.0%	0.1%	0.0%
12-04	Multi-instruction 4	-100.0% ~100.0%	0.1%	0.0%
12-05	Multi-instruction 5	-100.0% ~100.0%	0.1%	0.0%
12-06	Multi-instruction 6	-100.0% ~100.0%	0.1%	0.0%
12-07	Multi-instruction 7	-100.0% ~100.0%	0.1%	0.0%
12-08	Multi-instruction 8	-100.0% ~100.0%	0.1%	0.0%
12-09	Multi-instruction 9	-100.0% ~100.0%	0.1%	0.0%
12-10	Multi-instruction 10	-100.0% ~100.0%	0.1%	0.0%
12-11	Multi-instruction 11	-100.0% ~100.0%	0.1%	0.0%
12-12	Multi-instruction 12	-100.0% ~100.0%	0.1%	0.0%
12-13	Multi-instruction 13	-100.0% ~100.0%	0.1%	0.0%
12-14	Multi-instruction 14	-100.0% ~100.0%	0.1%	0.0%
12-15	Multi-instruction 15	-100.0% ~100.0%	0.1%	0.0%
12-16	Simple PLC running mode	0: Stop after the AC drive runs one cycle 1: Keep final values after the AC drive runs one cycle 2: Repeat after the AC drive runs one cycle	1	0
12-17	PLC power-down recall option	Unit : 0:not recall 1:recall Decade: 0:not recall 1:recall	11	00
12-18	PLC working time in 0 phase	0.0s(h) ~6553.5s(h)	0.1s(h)	0.0s(h)
12-19	PLC acceleration/deceleration time in 0 phase	0~3	1	0
12-20	PLC working time in 1 phase	0.0s(h) ~6553.5s(h)	0.1s(h)	0.0s(h)

12-21	PLC acceleration/deceleration time in 1 phase	0~3	1	0
12-22	PLC working time in 2 phase	0.0s(h) ~6553.5s(h)	0.1s(h)	0.0s(h)
12-23	PLC acceleration/deceleration time in 2 phase	0~3	1	0
12-24	PLC working time in 3 phase	0.0s(h) ~6553.5s(h)	0.1s(h)	0.0s(h)
12-25	PLC acceleration/deceleration time in 3 phase	0~3	1	0
12-26	PLC working time in 4 phase	0.0s(h) ~6553.5s(h)	0.1s(h)	0.0s(h)
12-27	PLC acceleration/deceleration time in 4 phase	0~3	1	0
12-28	PLC working time in 5 phase	0.0s(h) ~6553.5s(h)	0.1s(h)	0.0s(h)
12-29	PLC acceleration/deceleration time in 5 phase	0~3	1	0
12-30	PLC working time in 6 phase	0.0s(h) ~6553.5s(h)	0.1s(h)	0.0s(h)
12-31	PLC acceleration/deceleration time in 6 phase	0~3	1	0
12-32	PLC working time in 7 phase	0.0s(h) ~6553.5s(h)	0.1s(h)	0.0s(h)
12-33	PLC acceleration/deceleration time in 7 phase	0~3	1	0
12-34	PLC working time in 8 phase	0.0s(h) ~6553.5s(h)	0.1s(h)	0.0s(h)
12-35	PLC acceleration/deceleration time in 8 phase	0~3	1	0
12-36	PLC working time in 9 phase	0.0s(h) ~6553.5s(h)	0.1s(h)	0.0s(h)
12-37	PLC acceleration/deceleration time in 9 phase	0~3	1	0
12-38	PLC working time in 10 phase	0.0s(h) ~6553.5s(h)	0.1s(h)	0.0s(h)
12-39	PLC acceleration/deceleration time in 10 phase	0~3	1	0
12-40	PLC working time in 11 phase	0.0s(h) ~6553.5s(h)	0.1s(h)	0.0s(h)
12-41	PLC acceleration/deceleration time in 11 phase	0~3	1	0
12-42	PLC working time in 12 phase	0.0s(h) ~6553.5s(h)	0.1s(h)	0.0s(h)
12-43	PLC acceleration/deceleration time in 12 phase	0~3	1	0
12-44	PLC working time in 13 phase	0.0s(h) ~6553.5s(h)	0.1s(h)	0.0s(h)
12-45	PLC acceleration/deceleration time in 13 phase	0~3	1	0
12-46	PLC working time in 14 phase	0.0s(h) ~6553.5s(h)	0.1s(h)	0.0s(h)
12-47	PLC acceleration/deceleration time in 14 phase	0~3	1	0
12-48	PLC working time in 15 phase	0.0s(h) ~6553.5s(h)	0.1s(h)	0.0s(h)
12-49	PLC acceleration/deceleration time in 15 phase	0~3	1	0
12-50	PLC working time unit	0:second 1:hour	1	0
12-51	Multifunction 0 setting mode	0:function code 12-00 1:A11 2:A12 3:reserved 4:Pulse 5:PID 6:pre-set frequency (p0-08)	1	0

Group 13 Communication parameter				
13-00	Baud rate	Unit:MODBUS 0:300BPS 1:600BPS 2:1200BPS 3:2400BPS 4:4800BPS 5:9600BPS 6:1920BPS 7:3840BPS 8:5760BPS 9:115200BPS Decade:reserved Hundred:reserved Kilobit:reserved		6005
13-01	Data formate	0:not parity check (8-N-2) 1:even parity check(8-E-1) 2"odd parity check(8-0-1) 3:8-N-1	1	0
13-02	Local address	1~249,0 is broadcast address	1	1
13-03	Response delay	0ms ~20 ms	1ms	2
13-04	Communication overtime	0.0 (invalid),0.1s ~60.0s	0.1s	0.0
13-05	Data transfer formate option	Unit:MODBUS 0:non-standard MODBUS agreement	1	31
13-06	Communication readcurrent resolution	0:0.01A 1:0.1A	1	0

Group 16 : user password				
16-00	passwrod	0~65535	1	0
16-01	Restore default settings	0:no operation 01: Restore factory settings except motor parameters 02:clear the record	1	0

Chapter 6 Fault diagnosis and Countermeasures

Fault diagnosis and measures

The inverter has protection function for overvoltage, low voltage etc, once the abnormal fault occurs, protection module will be active, the inverter will stop, abnormal contact action and the motor stop running. Users can do self-examination suggests, analysis the causes of failure and find the solution refer to this section.

Fault Name	Panel Display	Fault Cause	Solution
Overcurrent in normal mode	OCN	<ol style="list-style-type: none"> 1. The inverter output circuit is short to ground. 2. to choose vector control mode without parameter recognition 3. voltage is lower 4. increase load when working 5. Inverter type is not suitable 	<ol style="list-style-type: none"> 1. eliminate the external fault 2. to recognize moto parameters 3. adjust The voltage to the normal range 4. cancel additional load 5. Choose the high-power inverter
Overcurrent in normal mode	OU	<ol style="list-style-type: none"> 1. Input voltage is too large 2. There is external drag when motor working 	<ol style="list-style-type: none"> 1. adjust the voltage to the normal range 2. Cancel additional power or install a braking resistor
Inverter unit protection	SC	<ol style="list-style-type: none"> 1. The inverter output is short to ground 2. The motor and the inverter cable is too long 3. Module is overheat 4. Internal inverter cable is loose 5. The main control board is abnormal 6. The drive plate is abnormal 7. Module is abnormal 	<ol style="list-style-type: none"> 1. eliminate the external fault 2. install electricity or output filter 3. Check air duct whether block up, the fan whether work well and exclude of problem 4. Insert all connecting line 5. Seek to technical support 6. Seek to technical support 7. Seek to technical support
Overvoltage in acceleration mode	OUA	<ol style="list-style-type: none"> 1. The input voltage is too high 2. There is external factor to influence motor running 3. The accelerate time is too short 4. Braking module and braking resistor is not installed 	<ol style="list-style-type: none"> 1. adjust the voltage s to the normal range 2. Cancel in addition power and install a braking resistor 3. Increate the acceleration time 4. install braking unit and braking unit and resistance
Oercurrent in deceleration mode	OCD	<ol style="list-style-type: none"> 1. The inverter output circuit is shortto ground. 2. to choose vector control mode without parameter recognition 3. The ddeceleration time is too short 4. voltage is lower 5. increase load in deceleration mode 	<ol style="list-style-type: none"> 1. eliminate the external fault 2. to recognize moto parameters 3. Increase the ddeceleration time 4. The voltage is changed to the normal range 5. cancel additional load 6. Install braking unit and braking unit and resistance

Fault Name	Panel Display	Fault Cause	Solution
		6. Braking module and braking resistor is not installed	
Overcurrent in acceleration mode	OCA	<ol style="list-style-type: none"> 1. The inverter output circuit is short to ground. 2. to choose vector control mode 3.The acceleration time is too short 4. Manual torque boost or V/Fcurve is not suitable 5. voltage is lower 6. start when motor is working 7. .increase load in acceleration mode 8. Inverter type is not suitable 	<ol style="list-style-type: none"> 1. eliminate the external fault 2. to recognize moto parameters 3. Increase the acceleration time 4.adjust torque or V/F curve 5. The voltage is changed to the normal range 6.start after the motor stops 7.cancel additional load 8. Install braking unit and braking
overvoltage in deceleration mode	OUd	<ol style="list-style-type: none"> 1.The input voltage is too high 2. There is external factor to influence motor running 3. The decelerate time is too short 4. Braking module and braking resistor is not installed 	<ol style="list-style-type: none"> 1. The voltage is changed to the normal range 2. Cancel in addition power or adding a braking resistor 3. Increasing the deceleration time 4. Install braking unit and braking unit and resistance
Motor overload	OL1	<ol style="list-style-type: none"> 1. check the motor protection parameters P9-01 2. Whether load is too large or the motor locked-rotor 3. Inverter type is not suitable 	<ol style="list-style-type: none"> 1.set this parameters correctly. 2. Reduce the load and to check the moter and mechanical 3. Choose high-power inverter
Controller power fault	UU	<ol style="list-style-type: none"> 1. The input voltage is out of spec 	<ol style="list-style-type: none"> 1.Adjust voltage to the range of specs
Module overheat	OH1	<ol style="list-style-type: none"> 1. The environment temperature is too high 2. Air duct blockage 3. Fan damage 4. Module thermistor damage 5. Variable module damage 	<ol style="list-style-type: none"> 1. Lower the surrounding temperature 2.Clear air duct 3.Change fan 4.Change module thermistor 5. Change variable module
Undervoltage fault	LU	<ol style="list-style-type: none"> 1. power down temporarily 2. The inverter input voltage is our of spec 3. The busbar voltage is abnormal 4. Bridge rectifier and a buffer resistor is abnormal 5. Driver is abnormal 6. The control board is abnormal 	<ol style="list-style-type: none"> 1.Reset 2. Adjust voltage to the range of specs 3. Seek to technical support 4. Seek to technical support 5. Seek to technical support 6. Seek to technical support

Fault Name	Panel Display	Fault Cause	Solution
Inverter overload	OL2	1. The load is too large or the motor locked-rotor 2. Inverter type is not suitable	1. Reduce the load , check the motor and Mechanical 2. Choose high power inverter
EEPROM Read and write fault	EP	1.EEPROM Chip damage	1.Change the control panel
Power-on time is out	UT	1. The accumulated power- on time is out	1. initializing the setting and clear records
external equipment fault	EF	1. fault signal is introduced through multifunctional terminal DI 2. fault signal is introduced through the virtual IO	1.Reset 2. Reset
Inverter hardware fault	EH	1. overvoltage 2. overcurrent	1.Deal with overvoltage fault 2.Deal with overcurrent fault
Communication fault	CE	1. The upper monitor is abnormal 2. Communication line is abnormal 3. Communication parameters of group I3 settings are not correct	1.Check the upper monitor cable 2. Check the communication line 3. set communication parameters correctly
Over time fault	OT	1. accumulated working time is out	1.initializing the setting and clear records
Load loss fault	LL	1. The running current of inverter is less than P9-64	1.check whether load lose or whether P9-64、 P9-65 is set correctly
Contactora fault	RL	1. The drive plate and power is abnormal 2. The contactor is abnormal	1.Change driver plate or change power board 2.Change contactor
Motor tuning fault	ER	1. The motor parameters are not set according to the nameplate 2. Time of parameters recognition is out	1. set motor according to the nameplate parameters 2.Check the cable of inverter to moto

Fault Name	Panel Display	Fault Cause	Solution
Over-heat fault	OH2	1 Temperature sensor cable loose 2. The motor is over-heat	1. Check temperature sensor cable 2. Reduce carried frequency or take other measures to reduce temprature
Current detection fault	CC	1. Check the Holzer device anomaly 2. The contactor is abnormal	1. Change the Holzer 2. Chang contactor
Short to ground fault	GF	1. Short to ground of motor	1. Change cable or motor
PID feedback loss fault	PD	1. PID feedback is less than the value 10-28 set	1. Check out PID feedback information or set suitable value 10-28
Pulse-by-pulse current limit fault	LC	Load is too heavy or locked-rotor occurs on motor. The AC drive power class is small.	Reduce load or check motor and mechanical conditions.
Output phase loss	LF	The cable connecting the AC drive and the motor is abnormal.	Check for wiring errors and ensure the output cable is connected properly. Correct wiring.

Chapter 7 Standard Specifications

Standard Specification

TYPE		SPECIFICATIONS						
220V	Horsepower capacity(HP)	0.5	1	2	3	5	7.5	
	Rated power(KW)	0.4	0.75	1.5	2.2	3.7	5.5	
	Rated capacity(KVA)	1.5	3.0	4.0	5.9	8.9	17	
	Rated current(A)	2.1	3.8	5.1	9.0	18	25	
380V	Horsepower capacity(HP)		1	2	3	5	7.5	10
	Rated power(KW)		0.75	1.5	2.2	3.7	5.5	7.5
	Rated capacity(KVA)		1.5	3.0	4.0	5.9	8.9	11
	Rated current(A)		2.1	3.8	5.1	9.0	13	17
Personalized function	The highest frequency	V/F control: 0~500Hz ,vector control:0~500Hz						
	Carrier frequency	0.5kHz~16kHz ;according to the load characteristics, can be adjusted carrier frequency automatically.						
	The input frequency resolution	Digital setting:0.01Hz ;simulation setting: the highest frequency *0.025%						
	Control mode	Open loop vector control(SVC), V/F control						
	Starting torque	0.5Hz/150%(SVC)						
	Speed range	1 : 1 0 0 (S V C)						
	The steady speed precision	+/-0.5%(SVC)						
	Overload capacity	150%rated current 60s;180%rated current 3s;						
	Torque boost	Automatic torque boost: manual torque boost0.1%~30.0%						
	V/F curve	In three ways: straight, multi-point type, square type;						
	Acceleration and deceleration curve	linear or S curve acceleration and deceleration mode: four kinds of acceleration and deceleration time; acceleration and deceleration time range0.0~6500.0s						
	DC brake	DC braking frequency: 0.00Hz~the maximum frequency; the braking time:0.0s~36.0s, braking action current value:0.0%~100.0%						
	Motor-driven control	Dynamic frequency range:0.00Hz~50.00Hz;motor-driven acceleration and deceleration time:0.0s~6500.0s						
	Simple PLC, multi-speed operation	Through the built-in PLC or control terminal to achieve 16 speed at most						
	Built-in PID	Can be convenient to realize closed-loop control of process control system)						
	Automatic voltage regulator(AVR)	When the power voltage changes,automatically keep the output voltage constant						
	Overvoltage and overcurrent stall control	Current and voltage automatically limit during the operation, prevent frequent over-voltage and over-current trip						
	Fast current limiting function	Maximum limit reduce overcurrent faults, protect the inverter operation						
	Torque limit and control	"excavator" characteristics, the automatic torque limit during the operation, prevent frequent over-current trip						
	Power on peripheral equipment safety self-inspection	can be realized on the peripheral devices safety inspection, such as grounding, short						
Common DC bus function	can realize multiple inverters of common DC bus function							
Run	Textile swing frequency control	multiple delta frequency control						
	Timing control	timing control function: set the time range 0h~65535h						
	Run the command channel	three channels:Operation panel given , control terminal given , serial communication port terminals are given. Through a variety of mode switching						
	The frequency of the source	total of 10 kinds of frequency source: given digital ,analog voltage given , analog current given, pulse given, serial port given. Through a variety of mode switching)						
	Auxiliary frequency source	10 kind of auxiliary frequency source .Flexible to realize the frequency tuning, frequency synthesis						
Environment	The input terminal	five digital input, one may make the high speed pulse input, up to a maximum of 100KHz; two analog input terminals, one can only be used as voltage input, another can be used as a voltage or current input						
	The output terminal	a high-speed pulse output terminal (optional for open collector type), 0kHz~100kHz square wave signal output, can realize output frequency setting, the output frequency and other physical quantity; a digital output terminal; a relay output terminal; an analog output terminals, respectively, the optional 0/4mA~20mAhuo 0/2V~10V, the output can be set frequency, the output frequency and other physical quantity						
Environment	The use of occasions	indoor, not direct sunlight, no dust, corrosive gas, flammable gas, oil mist, water vapor, water or salt etc.						
	Altitude	below 1000m						
	The environment temperature	-10C ~+40C (The environment temperature At 40C ~50C ambient temperature, amount to use)						
	Humidity	below95%RH, no beads of condensation						
	Vibration	below5.9m/s2(0.6g)						
Storage temperature	-20C ~+60C							

Matching list of braking resistor

The braking torque be increased through increasing the external resistance; the necessary braking torque depends on the specific demand of use. please select the suitable resistance from the following table, according to the purpose and capacity of inverter.

Inverter			Braking unit		Braking resistor	
Voltage	Max applicable motor capacity	Inverter Model	Model CDBR	Number of unit	Resistor Specification	Number of resistor
230V	0.4	0.4kW	Built-In		80W 200 Ω	1
	0.75	0.75kW			80W 200 Ω	1
	1.5	1.5kW			300W 100 Ω	1
	2.2	2.2kW			300W 70 Ω	1
	3.7	3.7kW			400W 40 Ω	1
	5.5	5.5kW			500W 30 Ω	1
440V	0.4	0.4kW			70W 750 Ω	1
	0.75	0.75kW			70W 750 Ω	1
	1.5	1.5kW			260W 400 Ω	1
	2.2	2.2kW			260W 250 Ω	1
	3.7	3.7kW			500W 150 Ω	1
	5.5	5.5kW			1000W 100 Ω	1
	7.5	7.5kW			1000W 75 Ω	1