



QMA(Shanghai) Electric Co., Ltd

A1200 Elevator Inverter



User Manual

Contents

Chapter 1 Product Introduction	3
1.1 Product Introduction	3
1.2 Nameplate	4
1.3 Model Numbering Description	4
1.4 Application Environment	5
Chapter 2 Wiring	6
2.1 Basic Wiring Diagram	6
2.2 Terminal & Wiring of Main Circuit	7
2.3 Terminals & Wiring of Control Circuit :	9
2.4 DI Numerical Input Terminal:	11
Chapter 3 PG Card Options	13
3.1 Table of A1200 Elevator Inverter PG Card Options	13
3.2 Wiring PG Card of Interface Board of Rotary Encoder for Elevator	14
Chapter 4 Inverter Operation and Commissioning	17
4.1 Terms of Elevator Inverter	17
4.2 Operation and Display Interface	18
4.3 Function Code Review and Operation	20
Chapter 5 Function Parameter Table	23
5.1 Description of Function Codes	23
5.2 Function Parameter Table	24
Chapter 6 Parameter Description	40
Chapter 7 Application & Debugging	82
7.1 Preset Speed Control Mode	82
Chapter 8 Troubleshooting	97
8.1 Faults and Troubleshooting	97
8.2 Common Faults and Handling Methods	102
Chapter 9 Specification	103
9.1 Major Parameters of A1200 Series Inverter	103
9.2 Technical Specification	103

Chapter 1 Product Introduction

1.1 Product Introduction

Thank you for purchasing Qma A1200 elevator inverter, which is a general purpose current torque vector control inverter characterized by high performance and ultra low noise. For the best use of this inverter and for your safety, please read this manual carefully. If you encounter any problems not described in the manual during use, please contact your local dealer or our technical personnel of Engineering Department. Our professionals are always pleased to serve you. You can feel free to continue to use A1200 elevator inverter.

[Notice for Use]:

A1200 is developed by Qma. In this manual, “Danger” and “Caution” paragraphs contain important safety precautions that shall be paid attention to during transportation, installation, operation and examination of the inverter.

[Danger]: Incorrect use of this inverter may result in personal injury and death. Do not dismount or install inverter or change its internal connection, wiring or component by yourself.

[Caution]: Incorrect use of this product may cause damages to the inverter or its mechanical systems.

[Danger]:

- After turning off the power, do not touch circuit board or components before CHARGE indicator goes off.
- Do not dismount or install inverter or change its internal connection, wiring or component by yourself.
- Make sure the power is off before wiring; do not check components, parts or signals on the circuit board while the inverter is running.
- Earthing terminals of the inverter must be grounded properly. Three grounding modes for 220V, special earthing for 440V.

[Caution]:

- Never perform withstanding voltage test for components or parts in the inverter, otherwise this may cause damages to these semi-conductor parts due to high voltage.
- Never wire output terminals U, V and W of the inverter to input terminals (R, S, T) of AC power supply.
- Component COMOSIC of inverter circuit board is susceptible to static electricity influence and damages. Do not touch the main circuit board.

[During operation]:

Danger
<ul style="list-style-type: none">• Never remove front cover under power-on state to avoid electric shock; otherwise, this may cause personal injury.• Never get close to the machine to avoid danger after motor stops working as it will automatically restart again if automatic restart function is enabled.• Stop switch will be effected only after setting. Please note that it is different from emergency stop switch in usage.

Notice
<ul style="list-style-type: none">• Never touch heating elements like heat sink and braking resistor to avoid electric shock; otherwise, it may cause personal injury.• The inverter can be easily changed from low speed to high speed. Please input the allowable range of motor and machinery.• When using brake, etc., please pay attention to relevant setting.• Never check signals of circuit board when the inverter is running.• Inverter has been set in the factory, so please do not adjust it arbitrarily.

1.2 Nameplate

Take 11kw 380V as an example

- Model ----->
- Input power ----->
- Output power ----->
- Output frequency ----->

- Barcode ----->
- Production control code ---->

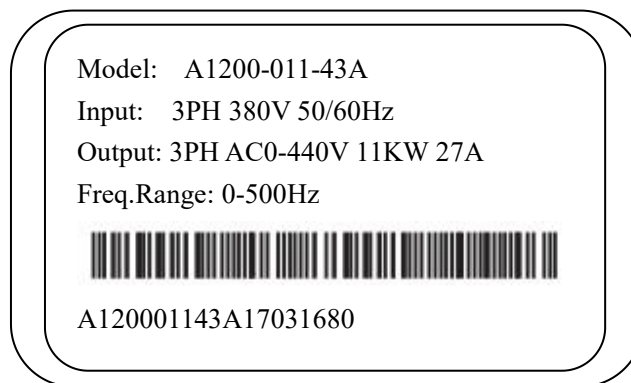

1.3 Model Numbering Description

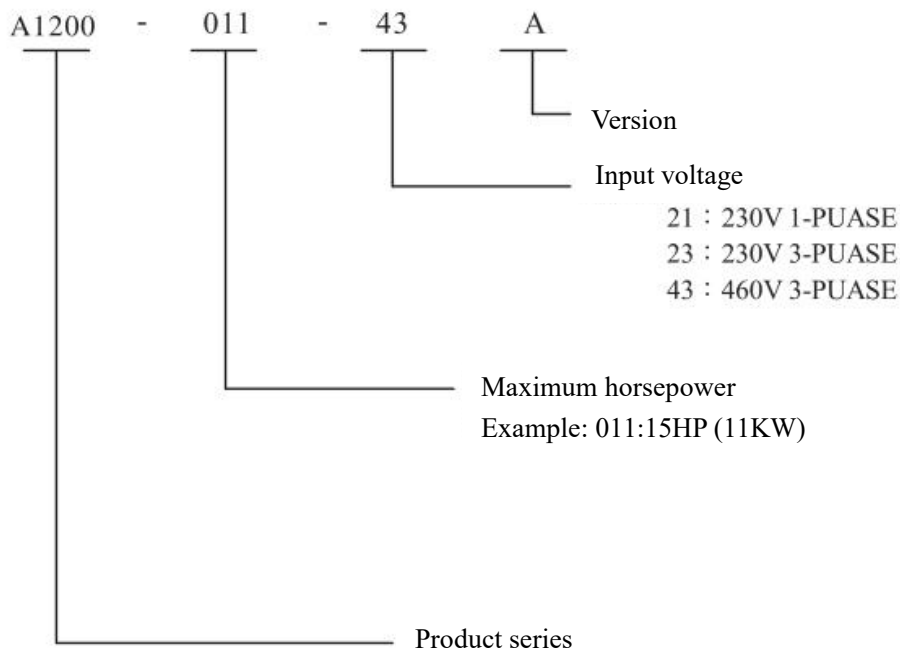

1.4 Application Environment

As the installation environment has direct influence on the performance and service life of the inverter, following conditions must be met.

- Ambient environment: Open installation in switchboard (-10-45°C/+14-113° F)
Closed wall-mounted type (-10-40°C/+14-104° F)
- Avoid rain or humid environment. Avoid direct sunlight.
- Prevent erosion of oil mist and salt. • Avoid corrosive liquid and gas.
- Prevent dust, batting and metal powder from entering the inverter.
- Away from radioactive substance and combustible material.
- Prevent electromagnetic interference (welding machine, power machine).
- Prevent vibration (punch press). If it is unavoidable, please install a shockproof gasket to reduce vibration.
- When multiple inverters are installed in a control cabinet, install them at proper positions for heat dissipation. In addition, please install a heat radiation fan to make the ambient temperature around the inverter lower than 45°C.

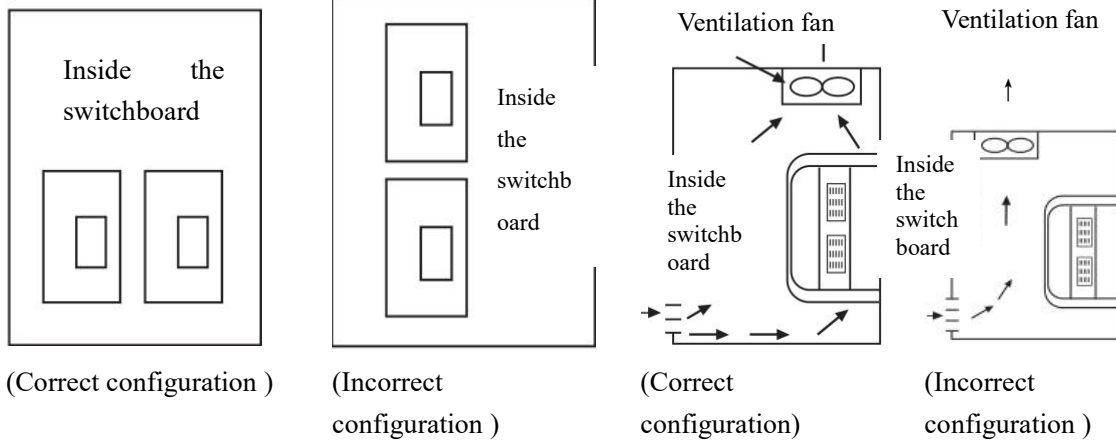

- Installing the inverter with its front surface forward and top part upward for heat radiation.
- Installation space must be in accordance with following regulations: When the inverter is installed inside the switchboard or if conditions permit, remove upper dustproof cover of the inverter for cooling and heat radiation.

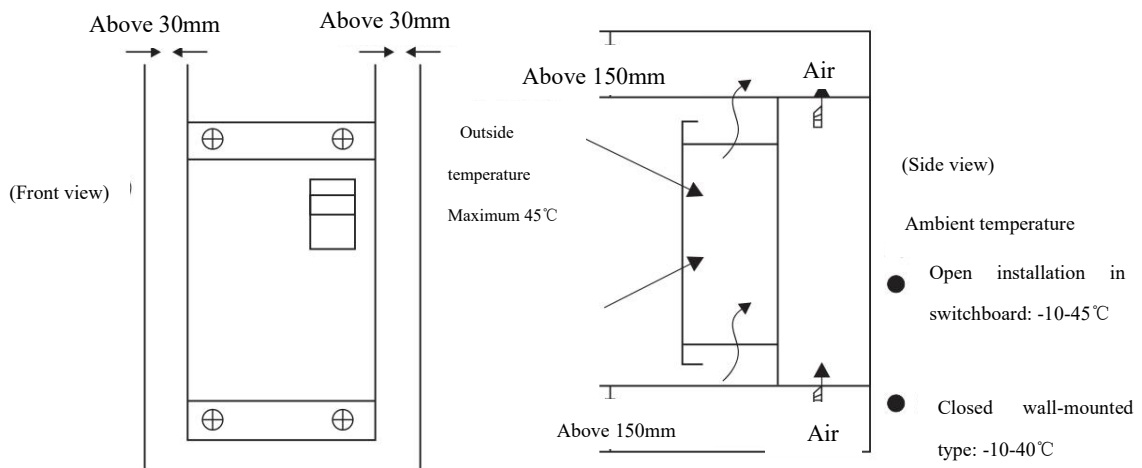

Chapter 2 Wiring

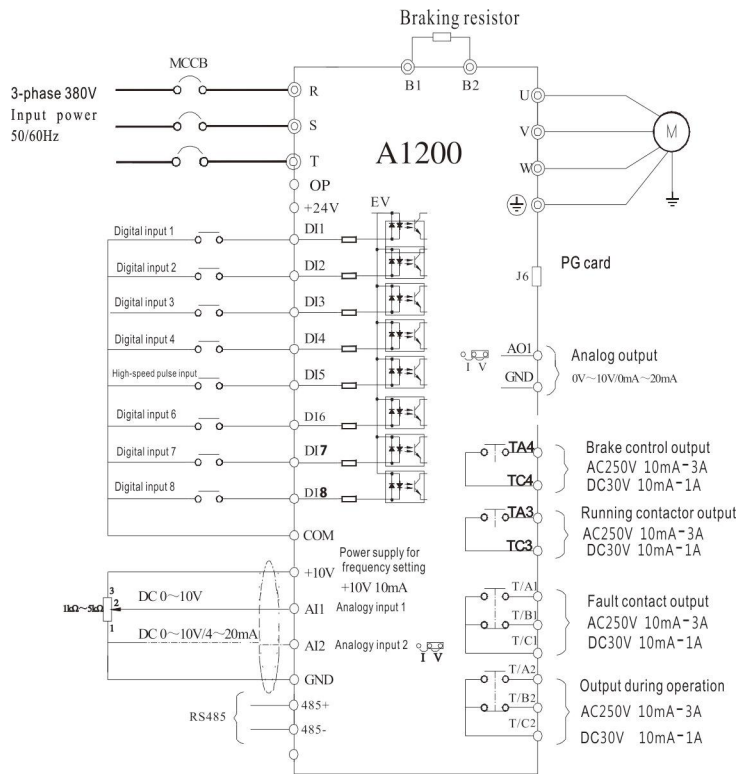

2.1 Basic Wiring Diagram

- Wiring Schematic Diagram of 3-phase Inverter



Wiring Schematic Diagram of 3-phase Inverter

Note:

- 1)  refers to main circuit terminal,  refers to control circuit terminal.
- 2) Select braking resistor as required by users. Please refer to Braking Resistor Selection Guide for detail.

2.2 Terminal & Wiring of Main Circuit



Danger

1. Make sure that the power switch is OFF before wiring so as to avoid electric hazard!
2. Wiring must be performed by qualified and trained personnel so as to avoid inverter damage and personnel injury!
3. Earthing terminals must be grounded reliably to avoid electrical hazard and fire!



Notice

1. Confirm that input power's rated values are identical to that of the inverter; otherwise, it may result in inverter damage!
2. Confirm that motor matches to the inverter; otherwise, it may damage motor or trigger inverter protection!

3. Never connect power supply to terminals U, V and W to avoid inverter damage!
4. Do not connect braking resistor to DC bus terminals (+) & (-) directly; otherwise this may cause fire.

■ **Wiring of main circuit**

This part introduces main circuit I/O wiring and grounding wire.

Wiring on input side of main circuit

Installation of wiring circuit breaker

A wiring circuit breaker (MCCB) corresponding to inverter power is required between the power supply and the input terminals.

- The capacity of MCCB shall be 2 times that of the rated current of the inverter.
- The time characteristics of MCCB must meet the time characteristics of the overheating protection of the inverter (1.5fold and 1min rated output current/1 minute)
 - If single MCCB is shared by two or more inverters or other device, the contact of fault output shall be connected to contractor that will cut the power as shown in the figure below.

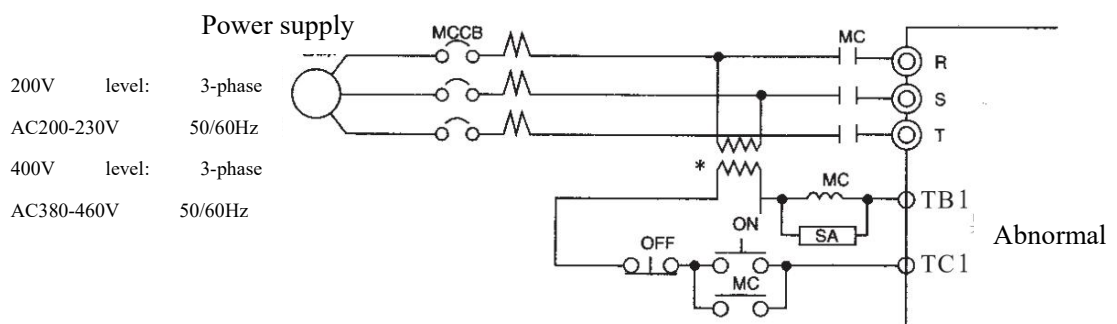

* When 400V level is selected, 400/200V transformer should be connected.

Setting Wiring Circuit Breaker

■ **Functions of Main Circuit Terminal**

Function	Terminal	A7000
Power input of main circuit	R, S, T	2.2-45KW
Inverter output	U, V, W	2.2-45KW
Connecting to braking resistor	B1, B2 (PB, +)	2.2-45KW
Connecting baking unit	⊕, ⊖	37-45KW
Grounding	⊕	2.2-45KW

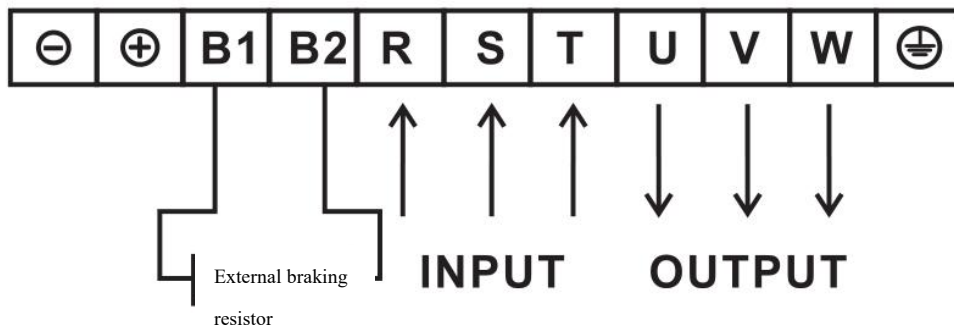

Example: A1200-011-43A

2.3 Terminals & Wiring of Control Circuit :

1) Layout drawing of control circuit terminals is as follows:

+10V	AI1	AI2	AO1	DI2	DI4	DI6	DI8	+24V	OP	T/A1	T/B1	T/C1	T/A3	T/C3
485+	485-	GND	DI1	DI3	DI5	DI7	COM	COM	CME	T/A2	T/B2	T/C2	T/A4	T/C4

2) Function of control circuit terminals:

Type	Terminal Symbol	Terminal Name	Terminal Function
Power supply	+10V-GND	External+10V	Offers +10 power source. Maximum output current: 10mA; generally used as a working power supply for external potentiometer. Resistance range of potentiometer: 1kΩ-1kΩ
	+24V-COM	External+24V	Offers +24 power source, generally used as a working power supply for numeric input and output terminals and an external sensor power supply. Maximum output current: 200mA.
	OP	External power supply input terminal	Default setting: connect to 24V power supply. When driving DI1 and DI8 with external power supply, connect it to the external power supply and pull out the connector between OP and +24V.
Analog input	AI1-GND	Analog input terminal 1	1. Input voltage range: DC OV_10V2. Input impedance: 22k Ω
	AI2-GND	Analog input terminal 2	1. Input range: DC OV 10V/4mA 20mA, determined by jumper wire on control

			board 2. Input impedance: voltage input 22kΩ, current input 500Ω
Numerical input	DI1	Numerical input 1	1. Optocoupler isolation, compatible with bipolar input 2. Input impedance: 2.4kΩ 3. Voltage range under level input: 9V-30V
	DI2	Numerical input 2	
	DI3	Numerical input 3	
	DI4	Numerical input 4	
	DI5	High-speed pulse input terminal	In addition to features of DI1-DI8, it can be used as high-speed pulse input channel as well. Maximum input frequency: 100kHz
	DI6	Numerical input 6	1. Optocoupler isolation, compatible with bipolar input 2. Input impedance: 2.4kΩ 3. Voltage range under level input: 9V-30V
	DI7	Numerical input 7	
	DI8	Numerical input 8	
Analog output	AO1-GND	Analog output 1	Determine voltage or current output by the jumper wire on control board. Output voltage range: 0V-10V Output current range: 0mA-20mA
Relay output	T/A1-T/C1	NO terminal	Contact driving capacity: AC250V, 3A, COSΦ=0.4. DC 30V, 1A
	T/B1-T/C1	NC terminal	
	T/A2-T/C2	NO terminal	
	T/B2-T/C2	NC terminal	Contact driving capacity: AC250V, 3A, COSΦ=0.4 DC 30V, 1A
	T/A3-T/C3	NO terminal	
	T/A4-T/C4	NO terminal	
Communication	485+	485 differential signal (+)	Standard RS485 communication port
	485-	485 differential signal (-)	

3) Wiring of control circuit terminals:

- For inductive loads like coil for driving relay, please be sure to insert bypass diode as shown in the figure below.
- Separate control circuit cables from cables of main circuit and other power cables or power supply cables in wiring.

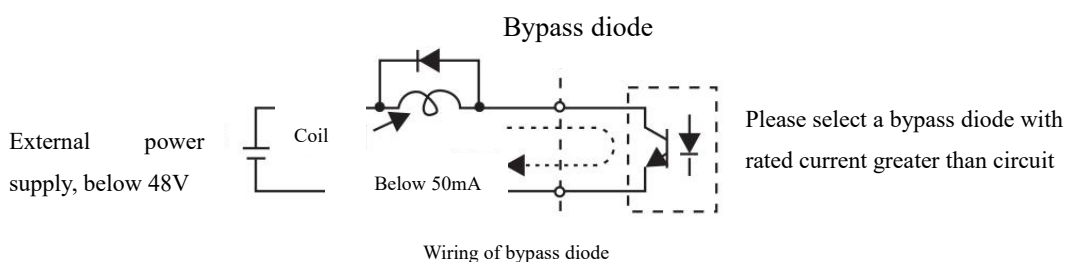

A1200 Series

- Please use twisted shielded cables or twisted pair cables to avoid malfunctions caused by interference. Please refer to the figure below for cable end treatment. The wiring distance should be less than 50m
- Please connect shielded net cables to earthing terminal (E).
- Wrap shielded net cables with insulating tape to prevent shielded net cables from contacting other signal cables and device housing.

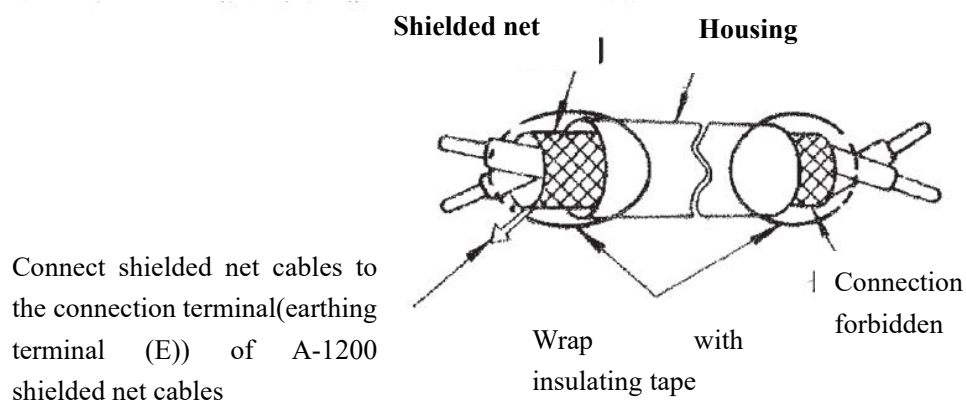

Wrapping ends of shielded twisted pair cables

2.4 DI Numerical Input Terminal:

Shielded cables are generally used and the wiring distance should be as short as possible and in a maximum of 20m. When adopting active drive, necessary filtration measures must be taken to prevent interference to power supply. Contact control mode is recommended.

PNP wiring mode

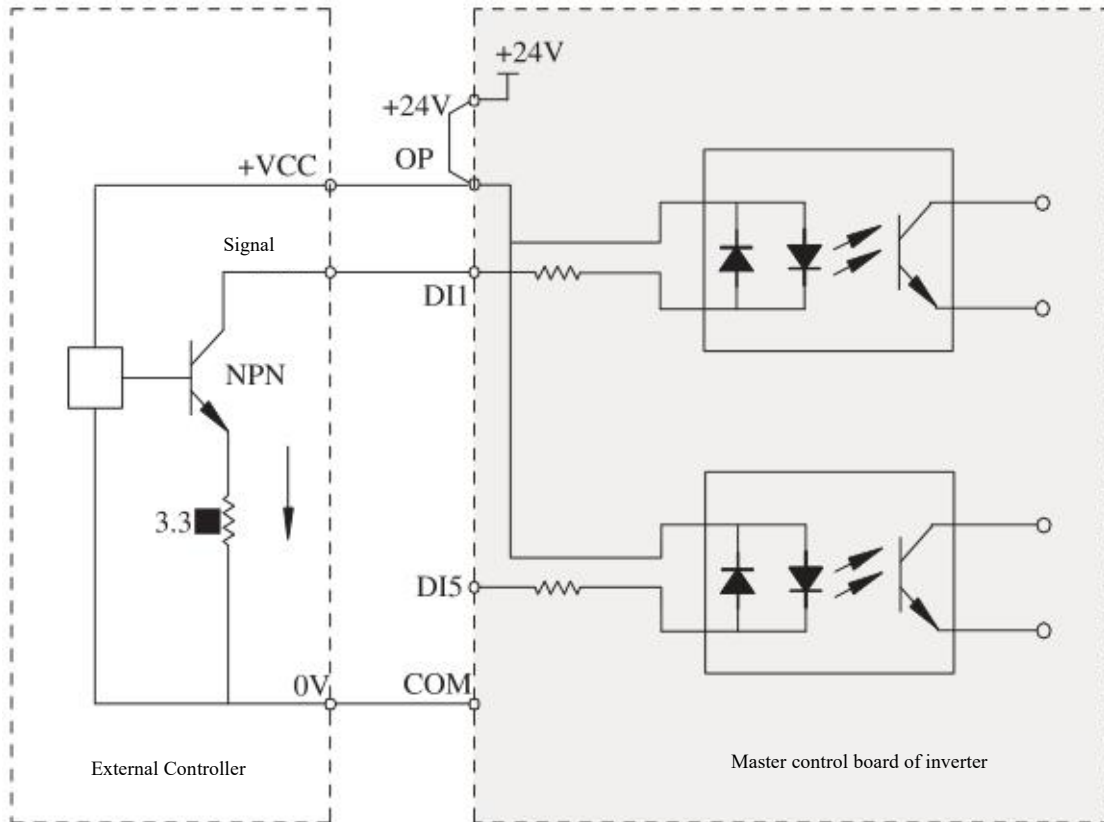

Figure 2-1 PNP wiring mode

This is the most common wiring method. When using external power supply, be sure to pull out the connector between OP and +24V (+). Then the external power supply 0V will be connected to corresponding DI terminal through inverter control contact.

- ◆ Note: Under this wiring mode, DI terminals of different inverters can not be connected in parallel, otherwise this may result in misoperation of DI; if it is required to connect DI terminals of different inverters in parallel, a diode must be wired at DI terminal ((+) connects to DI) in series. Diode should meet the following requirements: $I_F > 10\text{mA}$, $U_F < 1\text{V}$, as shown in the figure below.

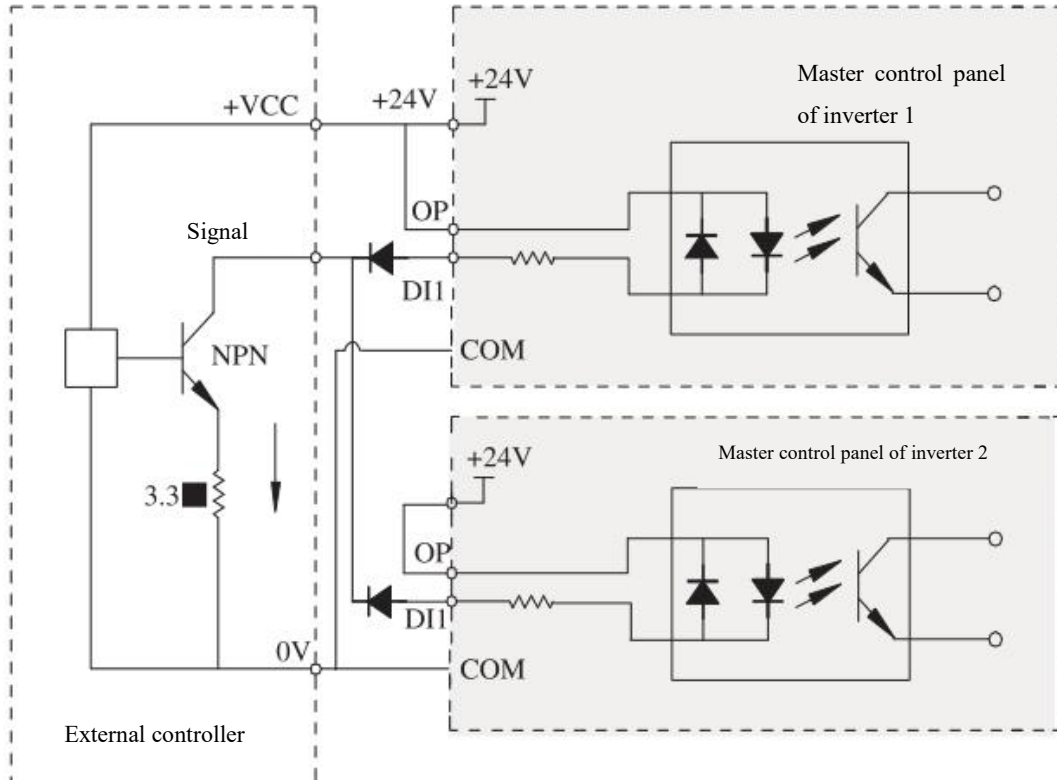

Figure 2-2 PNP Wiring Mode of DI Terminals of Multiple Inverters in Parallel Connection

Chapter 3 PG Card Options

3.1 Table of A1200 Elevator Inverter PG Card Options

Name	Model	Function	Remarks
External braking unit	CDBR	External braking units, with power \geq 37kW	See the appendix--Braking Resistor Selection Guide for details
PG card	QMA-PG-B	Rotary encoder interface card, frequency division output card	Provide 15V power supply, applicable to push-pull or open collector output incremental encoder; frequency division can be selected.
	QMA-PG-X	Rotary encoder interface card, frequency division output card	Provide 5V power supply, applicable to line driver incremental encoder and UVW encoder; frequency division signal OC output; frequency

			division can be selected.
	QMA-PG-C	Rotary encoder interface card, frequency division output card	Provide 5V power supply; sin, cos encoder; frequency division signal OC output; frequency division can be selected.
	QMA-PG-D	Rotary encoder interface card, frequency division output card	Provide 5V power supply; Endat encoder; frequency division signal OC output; frequency division can be selected.

3.2 Wiring PG Card of Interface Board of Rotary Encoder for Elevator

3.2.1 QMA-PG-B (applicable to incremental encoder with OC output and push-pull output used for induction motor)

1) Description of wiring

A1200 elevator inverter can be equipped with PG card with frequency division output and when wiring PG card, attentions shall be paid to the following matters:

- a) Separate cables between encoder and PG from cables of control circuit and power circuit. Parallel cabling of short distance is forbidden.
- b) Use shielded cables to wire between encoder and PG. Shielded layer shall be closer to one side of the inverter and connected to PE terminal (to prevent interference, only one terminal shall be grounded)
- c) Encoder and PG shall be wired in a separate pipe and metal pipe housing must be grounded reliably.

Figure 3.1: PG Card Wiring

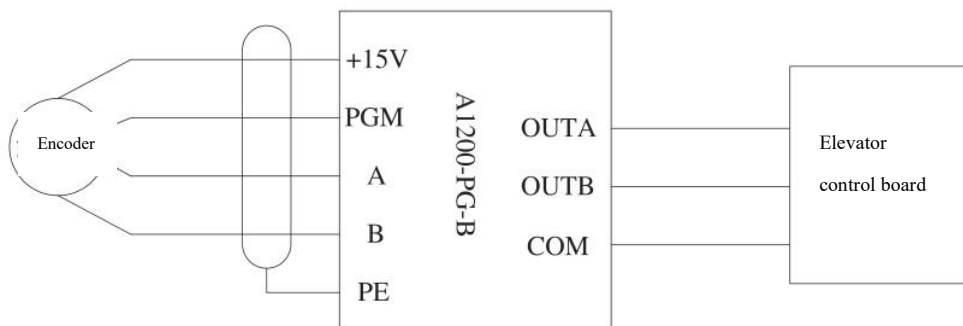

Figure 3.1 PG Card Wiring of QMA-PG-B Induction Motor

2) Technical parameters

Table 3.2 Technical Parameters

Terminal Symbol	Function	Response Speed	Output Impedance	Output Current	Frequency Division Range
+15V, COM	Provide power supply for encoder	-	About 300 Ω	300mA	-
PGA, PGB	Encoder signal access	0-60kHz	-	-	-
OUT-A OUT-B	Frequency division signal output	0-60kHz	About 30 Ω	100mA	1-64

3) Description of terminals and DIP

PG card includes seven user wiring terminals, of which +15PG and COM are as working power output terminals of encoder;

PGA and PGB are signal input terminals of encoder; OUT-A, OUT-B and COM are frequency division signal output terminals; PE is the shielded cable wiring terminal (PE in PG card is not grounded. Therefore, PE must be grounded when it is used.)

3.2.4 DIP switch: It is used to set the frequency division factor and filter function for frequency division output of PG card. There are 8 DIP switches in total.

Setting frequency division factor: 8 DIP bits correspond to different binary bits respectively. DIP switch indicated with “1” corresponds to low binary bit, while DIP indicated with “8” corresponds to high binary bit. When DIP switch is switched to ON, this bit is enabled and displayed as 1. Otherwise, it will be “0”. An example is given in the table below:

Table 3.3 Function Setting of DIP Switch

Frequency Division Factor Setting Switch								
Frequency division factor	8	7	6	5	4	3	2	1
No output	0	0	0	0	0	0	0	0
1 frequency division output	0	0	0	0	0	0	0	1
2 frequency division output	0	0	0	0	0	0	1	0
3 frequency division output	0	0	0	0	0	0	1	1
.
.
.
64 frequency division output	0	0	1	1	1	1	1	1

3.2.2 A1200-PG-X (applicable to UVW encoder of synchronous motor and line driver incremental encoder of induction motor)

1) Technical parameters

Terminal Symbol	Function	Response Speed	Output Impedance	Output Current	Frequency Division
-----------------	----------	----------------	------------------	----------------	--------------------

A1200 Series

					Range
VCC, GND	Provide power supply for encoder	-	About 300 Ω	300mA	-
A+, B+, A-, B-, U+, V+, W+, U-, V-, W-,	Encoder signal access	0-80kHz	-	-	-
OUT-A, OUT-B, COM	Frequency division signal output	0-80kHz	About 30 Ω	100mA	1

2) Description of terminals

PG card has 15 user wiring terminals, of which VCC and GND are output terminals of working power supply of encoder; A+, B+, A-, B-, U+, V+, W+, U-, V- and W- are signal input terminals of encoder; OUT-A, OUT-B and COM are output terminals of frequency division signal.

3) QMA-PG-X is connected to UVW encoder through D type 15-pin (DB15) connector. Definition of all pins of the connector is as follows:

Model of PG Adapter Card	Definition of Pins of DB15	Applicable Encoder
QMA-PG-X		UVW encoder

3.2.3 A1200-PG-C (applicable to ERN1387 sin/cos encoder used for synchronous motor)

1) QMA-PG-C is connected to ERN1387 sin/cos encoder through D type 15-pin (DB15) connector.

Definition of all connectors as follows:

Model of PG Adapter Card	Definition of Pins of DB15	Applicable Encoder
QMA-PG-C		ERN1387 sin/cos encoder

2) Description of terminals

PG card has 15 user wiring terminals, of which VCC and GND are output terminals of working power supply of encoder; A+, B+, A-, B-, Z+, Z-, C+, C-, D+ and D- are signal input terminals of encoder; OUT-A, OUT-B and COM are frequency division signal output terminals.

3.2.4 A1200-PG-D (applicable to ECN1313 Endat encoder used for synchronous motor)

1) QMA-PG-D is connected to ECN1313 Endat encoder by D type 15-pin (DB15) connector.

Definitions of all pins of the connector is as follows:

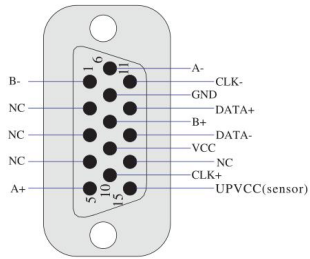
Model of PG Adapter Card	Definition of Pins of DB15	Applicable Encoder
QMA-PG-D		ECN1313Endat encoder

2) Description of terminals

PG card has 15 user wiring terminals, of which VCC and GND are output terminals of working power supply of encoder; A+, B+, A-, B-, NC, NC, CLK+, CLK-, DATA+ and DATA- are signal input terminals of encoder; OUT-A, OUT-B and COM are output terminals of frequency division signal.

Chapter 4 Inverter Operation and Commissioning

Overview: This chapter introduces the keypad operation and function code setting of operation panel of A1200 elevator inverter.

4.1 Terms of Elevator Inverter

Basic terms of A1200 elevator inverter include those ones for operation mode and system status.

4.1.1 Operation mode

The operation modes of inverter refer to which kind of method will be adopted to accept running commands and speed commands. A1200 elevator inverter can only run in one of the two control modes said below.

Operation panel control: Control inverter output through RUN and STOP of operation panel.

Terminal command control: Running commands and running speed are controlled by multi-function input terminals through input signals.

4.1.2 Control modes

A1200 elevator inverter supports three control modes

- 1) Sensorless vector control (SVC)
- 2) Feedback vector control (VC)
- 3) V/F control

4.1.3 Running modes

Autotuning mode: A1200 elevator inverter provides autotuning mode for a motor with load or without load. Please refer to description of parameter P1-11 for detail.

Normal running mode: Running under operation panel control and running under analog setting

Preset speed running: Under this mode, running speed is controlled by preset speeds.

Inverter can run only in one mode all the time.

4.1.4 Operation status

When the inverter is powered on, A1200 elevator inverter has four operation statuses: Stop status, programmable status, running status, fault alarm status.

Stop status:

After powered on again or stop after the running command ends, the inverter stays in the standby status until it receives a new running command. At this time, the running indicator goes off, LED contents flash as a whole and “>>” key can be pressed down to display different parameters circularly.

Programmable status:

User can check and set inverter parameters through operation panel. This means that inverter is in the programmable status,

Running status (elevator running):

When the inverter is in running status, the running indicator is on and contents displayed on LED are not flashing.

Fault alarm status:

Refer to the status of inverter under fault, with fault codes displayed.

4.2 Operation and Display Interface

The keypad with LED display is a standard part of A1200 elevator inverter. A user may operate A1200 elevator inverter by keypad through parameter setting, status monitoring, start/stop operation, etc.

The keypad appearance and function area is as shown in Figure 4 - 1.

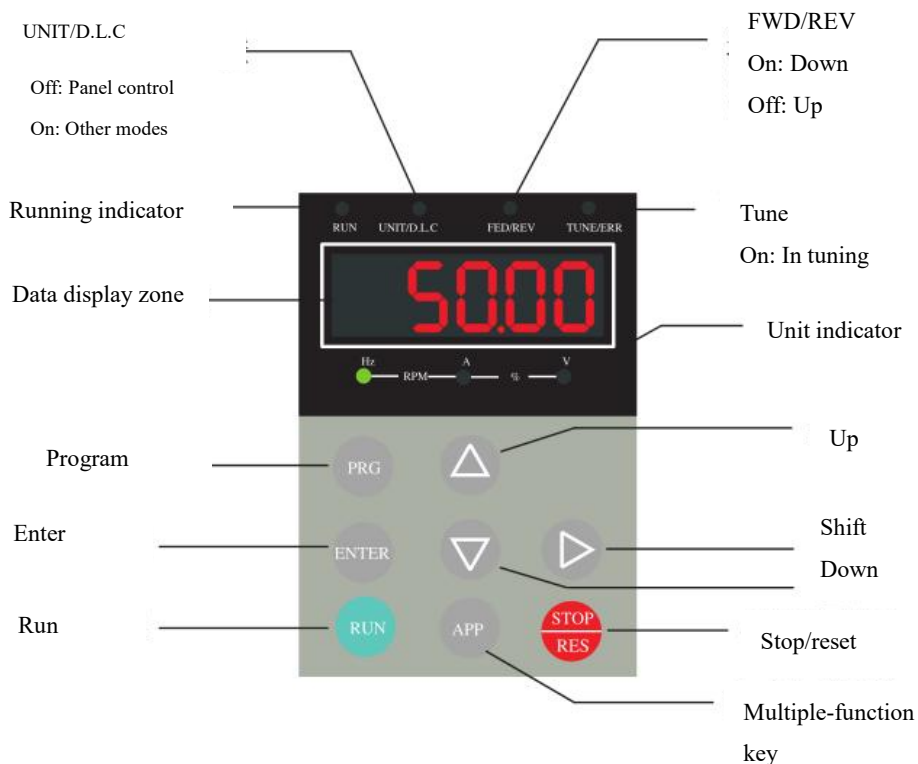

Figure 4-1 Operation Panel

1) Function indicator

- RUN: When the indicator is on, it means the inverter is in running status.
- UNIT/D.L.C: Running mode indicator. When the indicator is on, it means that the inverter is under operation panel control mode. Otherwise, it means that the inverter is under terminal control mode.
- FWD/REV: Running direction indicator. When the indicator is on, it means that the inverter goes down. Otherwise, the inverter goes up.
- TUNE: Tuning indicator. When the indicator is on, it means the inverter is in tuning status.

2) Digital display area

5-digit LED can be used to display the setting frequency, output frequency and various monitoring data and alarm codes.

3) Unit indicator

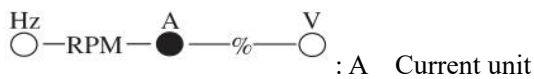
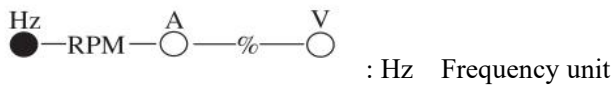

4) Functions of buttons of keypad

Button	Name	Function
	Programmable	Enter and exit the level 1 menu. Delete parameters quickly.
	Enter	Enter the menu step by step, set and enter parameters.
	Up	Increase figure or function code progressively.
	Down	Reduce figure or function code progressively.
	Shift	Select the display parameters of LED circularly under stop status and running status; when modifying parameters, it can be used to select the bit of parameters.

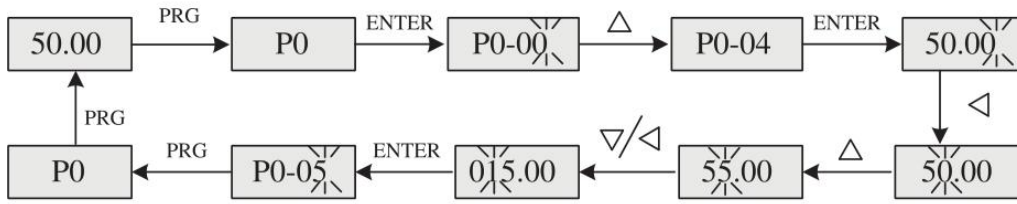

Figure 4-3 Example of Parameter Editing

Under the level 3 menu, if there is no flashing bit, it means that this function code can not be modified. Possible causes:

- 1) The function code is a parameter that can not be modified, such as actual detection parameter, operation log parameter.
- 2) This function code can not be modified under the running status. For modification, it is required to stop the inverter.

4.3.2 Operation method of status display parameters

Press down the shift button  to switch over status parameters:

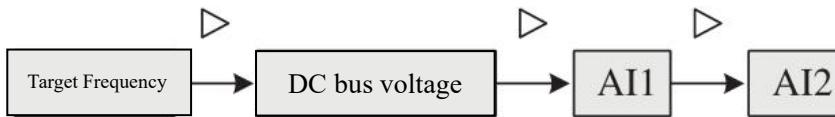





Figure 4-4 Switching Status Parameters

A1200 elevator inverter adopts LED to display various status parameters under stop status or running status. Specific parameters to be displayed shall be selected according to the binary bit of function code P8-01 (running display parameter) and P8-02 (stop display parameter). Moreover,

user may, through the shift button , display status parameters under stop or running status circularly.

When A1200 elevator inverter is under stop status, user can press  to display its eight stop status parameters circularly, which respectively are: Target linear speed, target frequency, DC bus voltage, AI1, AI2, car load (%), etc. user can select values to be displayed according to bit by

P8-02 (binary of conversion bit), and press  to display selected parameters in a sequence circularly.

13 running parameters of inverter under the running status: Load speed, running frequency, target frequency, DC bus voltage, output voltage, output current, AI1, AI2, car load (%), start compensation current (%), operating torque current (%), etc. Select parameters to be displayed according to bit by P8-01 (binary of conversion bit) and press  to display selected parameters in a sequence circularly.

Function code	Name	Setting Range	Minimum Unit	Default	Operational Properties
	Running	1-32767			

P 8-01	Parameter Display	Bit0: Load Speed Bit1: Running Frequency Bit2: Target Frequency Bit3: DC Bus Voltage Bit4: Output Voltage Bit5: Output Current Bit6: AI1 Bit7: AI2 Bit8: Car load (%) Bit9: Start Compensation Current (%) Bit10: Operating Torque Current (%) Bit11: Input Status Bit12: Output Status	1	32767	
P8-02	Stop Parameter Display	1-255 Bit0: Target Load Speed Bit1: Target Frequency Bit2: DC Bus Voltage Bit3: AI1 Bit4: AI2 Bit5: Car Load (%) Bit6: Input Status Bit7: Output status	1	255	

4.3.3 Read fault message

In the event of invert fault, fault code will be displayed on the panel. Users, through the fault code, can judge possible causes for fault and troubleshoot it as soon as possible.

A1200 elevator inverter can save the latest 11 fault codes and record the frequency, current, bus voltage, status of numeric input terminal and numeric output terminal upon occurrence of the last three faults. See figure 4-5:

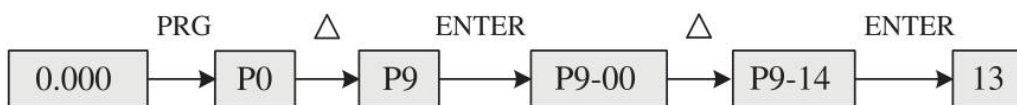

Stop parameter display

Figure 4-5 Method to View Fault Message

4.3.4 Monitor the status of numeric input and output terminal

During running, the inverter shall monitor the status of numeric input and output terminals. Please see Chapter 6 P8-00 Parameter Description for detail.

4.4 Password Setting

For protecting parameters more effectively, the inverter provides password protection for parameters.

The following shows the process to change the password to 12345.

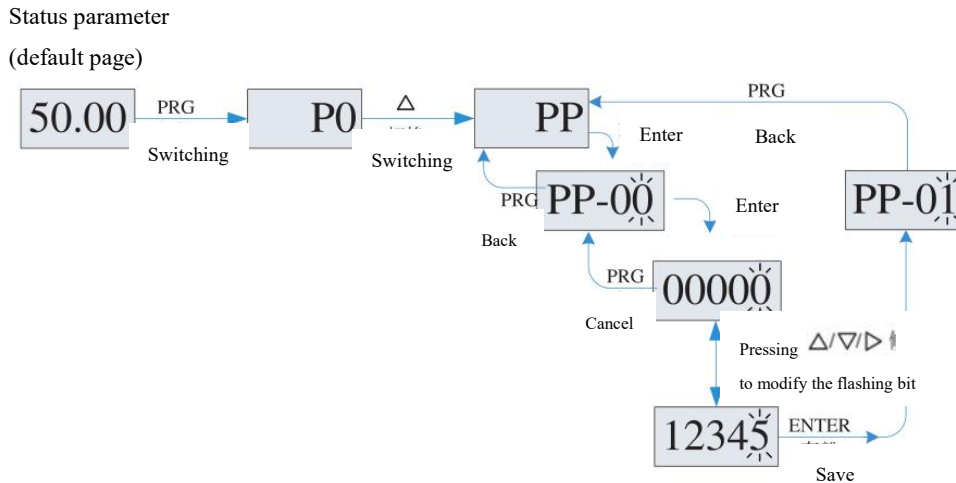



Figure 4-6 Password Setting Procedure

If a user password is set (PP-00 parameter is not zero) and when a user presses  to enter the function code editing status, the system will first enter the user password verification and login status, displayed as “-----”. For entering the system, operators are required to enter correct user password. In addition, manufacturers are also required to input correct manufacturer password for entering the manufacturer parameter setting area. (Note: Do not change the default parameter as wrong parameter setting may result in inverter fault or even damages.)

User can modify a user password that has not been locked at any time, and the last password entered shall be considered as the user password.

For disabling password protection function, user shall enter the system by password and set PP-00 as 0; if PP-00 is not set as 0 when the inverter is powered on, then this parameter is protected by passwords.

Chapter 5 Function Parameter Table

5.1 Description of Function Codes

1. Based on the function of function parameters, A1200 elevator inverter includes 18 groups of function codes, such as P0-P9, PA-PD, PU, PJ, PF and PP, each group having multiple function codes. Function codes are displayed in three-level menu. Words “PX-XX” mentioned in other parts in this manual refer to No. “XX” function code of the group “X”. For example, “P9-08” refers to the No.8 function code of the group P9.

In order to set function codes, on operation panel, the number of function group corresponds to the level 1 menu, the number of function code corresponds to the level 2 menu and function code parameter corresponds to the level 3 menu.

2. All columns of function parameter table are described as follows:

The first column “Function code”: No. of the function parameter group and parameter; the second

column “Name”: Complete names of function parameters; the third column “Setting range”: Range of effective setting value, displayed by LED; the fourth column “Minimum Unit”: Minimum unit of function parameter setting values; the fifth column “Default”: Default of function parameter; the sixth column “Property”: Property of function parameters (whether the operation is allowed and operating conditions). Descriptions are as follows:

“”: Refer to that A1200 elevator inverter is in the stop and running status and the parameter can be modified.

“®”: Refer to that A1200 elevator inverter is in the running status and the parameter can not be modified.

“●”: Refer to that this parameter value is the value recorded through actual test and can not be modified.

(In order to help user to avoid misoperation, the system has checked and restricted the change property of all parameters automatically)

3. “Default”: Refer to the value of function code refreshed when reset to the default; however, actual detection value or recorded value can not be refreshed.

4. In order to protect parameters more effectively, the system has password protection function for function code (see Chapter 4).

5.2 Function Parameter Table

5.2.1 Grouping function parameters

After PRG is pressed down, all level 1 menus displayed by pressing UP/DOWN represent groups of function groups. Specific information is as follows:

P0	Basic Parameter	P9	Fault and Protection Parameter
P1	Motor Parameter	PA	PG Parameter
P2	Vector Control Parameter	PB	Communication Parameter
P3	Start/stop Control Parameter	PC	Special Enhancement Function Parameter
P4	Input Function Parameter	PD	Special Function Parameter
P5	Output Function Parameter	PU	Monitoring Parameter
P6	Speed Parameter	PJ	Not Used Parameter
P7	Curve Parameter	PF	Default Parameter
P8	Keypad and Display Parameter	PP	User Parameter

5.2.2 Function parameter table

Function code	Name	Setting Range	Minimum Unit	Default	Property
P0-Basic Parameter					
P0-00	Control Mode	0: Sensorless vector control (SVC) 1: Feedback Vector control (VC) 2: V/F control	1	1	®
P0-01	Command Options	0: Running command channels of operation panel 1: Terminal running command	1	1	®

A1200 Series

		channels			
P0-02	Speed Options	0: Numeric setting 1: Preset speed 2: AI1 3: AI2 4: Not used 5: Special Preset speed	1	1	®
P0-03	Numeric Setting Frequency	0.00-maximum frequency	0.01Hz	00.00Hz	
P0-04	Running Direction	0: Same 1: Opposite	1	0	®
P0-05	Maximum Frequency	0.00Hz-90.00Hz	0.01Hz	50.00Hz	®
P0-06	Carrier Frequency	0.5kHz-16.0kHz	0.1kHz	Up to specific model	
P0-07	Carrier Frequency Adjustment	0: Fixed PWM 1: Random PWM	1	0	
P1 Motor Parameter					
P0-00	Encoder Type	0: SIN/COS 1: UVW 2: ABZ	1	1	®
P1-01	Rated Power	0.4kW-110.0kW	0.1kW	Up to specific model	®
P1-02	Rated Voltage	100-500V	1V	Up to specific model	®
P1-03	Rated Current	0.00-655.00A	0.01A	Up to specific model	®
P1-04	Rated Frequency	0-Maximum frequency	0.01Hz	50.00Hz	®
P1-05	Rated Rotation Speed	0-30000rpm	1rpm	1460rpm	®
P1-06	Not Used	0-65535	1	0	®
P1-07	Power Failure Angle of Synchronous Motor	0.0-359.9	0.1	0.0	®
P1-08	Not Used	0-65535	1	0	®
P1-09	Current Filter Factor of Synchronous Motor	0.0-3.0	0.1	0	®
P1-10	Encoder Parity	0-65535	1	0	®
P1-11	Motor tuning	0: No operation 1: Tuning for a motor with load 2: Tuning for a motor without load	1	0	®
P1-12	Not Used	0-65535	1	0	®
P1-13	Not Used	0-65535	1	0	®

A1200 Series

P1-14	Stator Resistor	0.001 Ω -65.000 Ω	0.001 Ω	Up to specific model	
P1-15	Rotor Resistor of Induction Motor	0.001 Ω -65.000 Ω	0.001 Ω	Up to specific model	
P1-16	Leakage Inductance of Induction Motor	0.01mH-650.00mH	0.01mH	Up to specific model	
P1-17	Mutual Inductance of Induction Motor	0.01mH-6500.00mH	0.1mH	Up to specific model	
P1-18	Idling Current of Induction Motor	0.01A-650.00A	0.01A	Up to specific model	
P1-19	D-shaft Inductance of Synchronous Motor	0.01mH-650.00mH	0.01mH	0.01mH	®
P1-20	Q-shaft Inductance of Synchronous Motor	0.01mH-650.00mH	0.01mH	0.01mH	®
P1-21	Back Electromotive Force of Synchronous Motor	0-65535V	1V	0V	®
P1-25	Motor Type	0: Induction motor 1: Synchronous motor	1	1	®
P2 Vector Control Parameter					
P2-00	Speed Loop Proportional Gain 1	0-100	1	35	
P2-01	Speed Loop Integral Time 1	0.01s-10.00s	0.01s	0.60s	
P2-02	Switching Frequency 1	0.00-P2-05	0.01Hz	2.00Hz	
P2-03	Speed Loop Proportional Gain 2	0-100	1	30	
P2-04	Speed Loop Integral Time 2	0.01s-10.00s	0.01s	0.80	
P2-05	Switching Frequency 2	P2-02-Maximum frequency	0.01Hz	5.00Hz	
P2-06	Current Loop Proportional Gain	10-500	1	60	
P2-07	Current Loop Integral Gain	10-500	1	30	
P2-08	Upper Limit of Torque	0.0%-200.0%	0.1%	150.0%	
P2-09	Torque Acceleration Time	1ms-500ms	1ms	1ms	®
P2-10	Torque Deceleration time	1ms-500ms	1ms	350ms	®
P2-11	Speed Filter Factor	1-20	1	10	®
P2-12	Angle-free autotuning function	0-65535V Bit1: 0 Disabled 1 Enabled Bit2: 0 semi-automatic 1 Full-automatic	1	0	®
P3 Start/Stop Control Parameter					
P3-00	Start Frequency	0.00Hz-10.00Hz	0.01Hz	0.00Hz	

A1200 Series

P3-01	Torque Output Delay	0.00s-10.00s	0.01s	0.20s	®
P3-02	Brake Open Delay	0.20s-10.00s	0.01s	0.20s	®
P3-03	Zero Speed Delay	0.00s-10.00s	0.01s	0.30s	®
P3-04	Start Time	0.00s-10.00s	0.01s	0.00s	®
P3-05	Start Frequency Holding Time	0.00s-10.00s	0.01s	0.00s	®
P3-06	Brake Release Delay	0.00s-10.00s	0.01s	0.20s	®
P3-07	Stop Zero Speed Delay	0.00s-10.00s	0.01s	0.30s	®
P3-08	Running Contactor Release Delay	0.00s-10.00s	0.01s	0.00s	®
P3-09	Start Pre-torque Setting	0: No pre-torque 1: DI setting 2: AI1 setting 3: AI2 setting 4: Enable pre-torque initial offset 5: No weighing compensation	1	0	®
P3-10	Pre-torque Shift	0.0%-100.0%	0.1%	48.0%	®
P3-11	Pre-torque Gain	0.00-1.50	0.01	0.60	®
P3-12	Initial Offset of Pre-torque	-100.0%-100.0%	0.1%	10.0%	®
P3-13	DI Weighing Signal 1	0.0%-100.00%	0.1%	10.0%	®
P3-14	DI Weighing Signal 2	0.0%-100.00%	0.1%	30.0%	®
P3-15	DI Weighing Signal 3	0.0%-100.00%	0.1%	70.0%	®
P3-16	DI Weighing Signal 4	0.0%-100.00%	0.1%	90.0%	®
P3-17	Weighing Analog Input Filter Time	0.00s-1.00s	0.01s	0.10s	
P3-18	Corresponding Input of Weighing Analog Idling	0.00V-10.00V	0.01V	0.00V	
P3-19	Corresponding Input of Weighing Analog Full Load	0.00V-10.00V	0.01V	10.00V	
P3-20	Analog Weighing autotuning	0-100	1	0	
P3-21	Analog Weighing Autotuning Options	0: No operation 1: Autotuning permitted	1	0	
P3-22	Pre-torque Direction Reverse	0: Same 1: Reverse	1	0	
P3-24	Slipping Test Function Options	0: Disabled 1: Enabled	1	0	®
P4 Input Function Parameter					
P4-00	DI Filter Time	0.001s-0.200s	0.001	0.020s	
P4-01	DI1 Terminal Function	0: No function	1	1	®

A1200 Series

P4-02	DI2 Terminal Function	1: Forward Command(FWD, Up) 2: Reverse Command (REV, Down) 3: Preset speed terminal 1 4: Preset speed terminal 2 5: Preset speed terminal 3 6: Fault reset 7: Enable control 8: Inspection input 9: Emergency input 10: Running contactor feedback 11: Brake feedback 12: Weighing terminal 1 13: Weighing terminal 2 14: Weighing terminal 3 15: Weighing terminal 4 16: External fault 17: Motor overheating 18: Up speed judgment 19: Down speed judgment 20: Preset speed logic option 1 21: Preset speed logic option 2 22: Direct stop command Terminal input range: 0-122; if the hundreds place is 1, it means this signal is normally closed and effective; 2 low places refer to terminal input functions. If it is greater than 22, this function is disabled. For example: 106. It means this terminal function is the fault reset function and the signal is normally closed.	1	2	®
P4-03	DI3 Terminal Function		1	3	®
P4-04	DI4 Terminal Function		1	4	®
P4-05	DI5 Terminal Function		1	5	®
P4-06	DI6 Terminal Function		1	6	®
P4-07	DI7 Terminal Function		1	7	®
P4-08	DI8 Terminal Function		1	0	®
P4-09	DI9 Terminal Function		1	0	®
P4-10	DI10 Terminal Function		1	0	®
P4-11	Not Used		1	0	®
P4-12	Not Used		0-65535	1	0
P4-13	Preset Speeds Filter Time	0.000s-0.200s	0.001	0.020s	
P5 Output Function Parameter					
P5-00	Not Used	0: No output	1	15	®

A1200 Series

P5-01	TA3-TC3 Output	1: Running 2: Zero speed running (enabled under zero speed running conditions)	1	6	®
P5-02	TA4-TC4 Output	3: Zero speed signal (output at stop) 4: Fault signal 5: Running contactor output control	1	5	®
P5-03	TA1-TB1-TC1 Output	6: Brake output control 7: Advance door opening signal 8: Bus undervoltage	1	4	®
P5-04	TA2-TB2-TC2 Output	9: FDT 1 output 10: FDT 2 output 11: Frequency reach 12: Overspeed output 14: Running time reach 15: Running ready 16: Contact adhesion output control	1	1	®
P5-05	Not Used	17: Releveling output 18: Light load running output Note: FDT: Frequency detection function. Detect the output frequency of the inverter itself, compare the detection value with the setting value and then control corresponding output terminal according to the comparison result	1	0	®
P5-06	Zero Speed Output Lag Time	0.000s-2.000s	1	0.000s	®
P5-07	AO Output	0: Running frequency 1: Setting frequency 2: Output current 3: Output torque 4: Output voltage 5: AI1 6: AI2	1	0	®
P5-08	AO Zero Offset	-100.0%-100.0%	0.1%	0.0%	
P5-09	AO Gain	-10.00-10.00	0.01	1.00	
P6 Speed Parameter					

A1200 Series

P6-00	Preset Speed 0	0-Maximum frequency	0.01Hz	0.00Hz	®
P6-01	Preset Speed 1	0-Maximum frequency	0.01Hz	0.00Hz	®
P6-02	Preset Speed 2	0-Maximum frequency	0.01Hz	0.00Hz	®
P6-03	Preset Speed 3	0-Maximum frequency	0.01Hz	0.00Hz	®
P6-04	Preset Speed 4	0-Maximum frequency	0.01Hz	0.00Hz	®
P6-05	Preset Speed 5	0-Maximum frequency	0.01Hz	0.00Hz	®
P6-06	Preset Speed 6	0-Maximum frequency	0.01Hz	0.00Hz	®
P6-07	Preset Speed 7	0-Maximum frequency	0.01Hz	0.00Hz	®
P6-08	Preset Speed 0 Acceleration/Deceleration Curve	1-4	1	1	®
P6-09	Preset Speed 1 Acceleration/Deceleration Curve	1-4	1	1	®
P6-10	Preset Speed 2 Acceleration/Deceleration Curve	1-4	1	1	®
P6-11	Preset Speed 3 Acceleration/Deceleration Curve	1-4	1	1	®
P6-12	Preset Speed 4 Acceleration/Deceleration Curve	1-4	1	1	®
P6-13	Preset Speed 5 Acceleration/Deceleration Curve	1-4	1	1	®
P6-14	Preset Speed 6 Acceleration/Deceleration Curve	1-4	1	1	®
P6-15	Preset Speed 7 Acceleration/Deceleration Curve	1-4	1	1	®
P6-16	Inspection Speed	0-7	1	0	®
P6-17	Power Failure Emergency Running	0: No operation 1: UPS operation 2: Power supply by 48v battery	1	0	®
P6-18	Minimum Input of Analog	0.00V-10.00V	0.01V	0.00V	
P6-19	Corresponding Setting of Minimum Input of Analog	0.0%-100.0%	0.1%	0.0%	
P6-20	Maximum Input of Analog	0.00V-10.00V	0.01V	10.00V	
P6-21	Corresponding Setting of	0.0%-100.0%	0.1%	100.0%	

A1200 Series

	Maximum Input of Analog				
P6-22	Analog Input Filter Time	0.00s-1.00s	0.01s	0.10s	
P6-23	Inverter Function 1	0-65535 Bit0: 0 Stop directly after releasing brake 1 After releasing brake, remove current firstly and then stop Bit1: 0 During autotuning, no-weighing compensation is disabled 1 No-weighing compensation works all the time Bit2: 0 When the inverter stops, run the command to prevent shaking 1 No shaking prevention Bit4: 0 Upper limit of maximum frequency is 90Hz 1 Maximum frequency is equal to rated frequency Bit5: 0 Analog setting is calculated according to maximum frequency 1: Calculate according to rated frequency	1	48	
P6-24	Voltage Setting at Motor Overheating	0.00V-11.00V	0.01V	0.0V	
P6-25	Inverter Function 2	0-65535 Bit0: 0 Detect SPI communication fault 1 No detection Bit1: 0 Parameters PA-03 and PA-05 can not be changed under the non-operation panel control mode, and after	1	0	

A1200 Series

		<p>change, P0-01 can not be changed</p> <p>1 Changeable</p> <p>Bit2:</p> <p>0 Fault Err33, 16 or 17 can not be reset</p> <p>1. Can be reset</p> <p>Bit3:</p> <p>0 During emergency running, no-weighing restart function is disabled</p> <p>1 During emergency running, no-weighing restart enabled</p> <p>0 Under terminal commands of synchronous motor, the inverter is limited to closed-loop vector control</p> <p>1 No restriction</p> <p>Bit5:</p> <p>0 Only when the running frequency is greater than 1/4 of the rated frequency, detect if the speed deviation is too big</p> <p>1 Detect if the speed deviation is too big immediately upon start</p>			
P6-27	Zero Speed Signal Output Delay	0ms-9999ms	1	0	
P6-28	Upper Limit of Power Failure Emergency Running Speed	0.00Hz-Maximum frequency	0.01Hz	8.00Hz	®
P7 Curve Parameter					
P7-00	Acceleration Time 1	1.0s-100.0s	0.1s	4.0s	
P7-01	Deceleration Time 1	1.0s-100.0s	0.1s	4.0s	
P7-02	S Curve 1 Start Section Proportion	10.0%-40.0%	0.1%	40.0%	®
P7-03	S Curve 1 End Section Proportion	10.0%-40.0%	0.1%	40.0%	®
P7-04	Acceleration Time 2	1.0s-100.0s	0.1s	4.0s	
P7-05	Deceleration Time 2	1.0s-100.0s	0.1s	4.0s	
P7-06	S Curve 2 Start Section Proportion	10.0%-40.0%	0.1%	40.0%	®
P7-07	S Curve 2 End Section	10.0%-40.0%	0.1%	40.0%	®

A1200 Series

	Proportion				
P7-08	Acceleration Time 3	1.0s-100.0s	0.1s	4.0s	
P7-09	Deceleration Time 3	1.0s-100.0s	0.1s	20.0s	
P7-10	S Curve 3 Start Section Proportion	10.0%-50.0%	0.1%	40.0%	®
P7-11	S Curve 3 End Section Proportion	10.0%-50.0%	0.1%	40.0%	®
P7-12	Acceleration Time 4	0.5s-100.0s	0.1s	1.0s	
P7-13	Deceleration Time 4	0.5s-100.0s	0.1s	1.0s	
P7-14	S Curve 4 Start Section Proportion	10.0%-50.0%	0.1%	40.0%	®
P7-15	S Curve 4 End Section Proportion	10.0%-50.0%	0.1%	40.0%	®
P7-16	Slipping Test Acceleration Time	0.5s-10.0s	0.1s	1.0s	®
P7-17	Direct Stopping Distance Setting	0.0mm-6553.5mm	0.1mm	0.0mm	®
P7-18	Actual Running Distance at Direct Stop	0.0mm-6553.5mm	0.1mm	0.0mm	●
P8 Keypad and Display Parameter					
P8-00	Status Indicator of Input and Output Terminals	-	-	-	●
P8-01	LED Running Display Parameter	1-32767 Bit0: Load speed Bit1: Running frequency Bit2: Target frequency Bit3: DC bus voltage Bit4: Output voltage Bit5: Output current Bit6: AI1 Bit7: AI2 Bit8: Car load (%) Bit9: Start compensation current (%) Bit10: Running torque current (%) Bit11: Input status Bit12: Output status	1	32767	
P8-02	LED Stop Display Parameter	1-255 Bit0: Target load speed Bit1: Target frequency Bit2: DC bus voltage Bit3: AI1	1	255	

A1200 Series

		Bit4: AI2 Bit5: Car load (%) Bit6: Input status Bit7: Output status			
P8-03	Elevator Rated Speed	0.001m/s-8.000ms	0.001m/s	1.600m/s	
P8-04	Radiator Temperature	0°C-100°C	1°C	-	●
P8-05	Control Board Software Version No.	0.00-99.99	0.01	-	●
P8-06	Not Used				
P8-07	Setting Running Time	0h-65500h 0: Disabled	1h	0h	
P8-08	Accumulated Working Time	0h-65500h	1h	0h	●
P8-09	Accumulated Seconds Count	0s-3600s	1s	0s	●
P8-10	High Bit of Running Times	0-9999 Note: 1 refers to actual running times 10000	1	0	●
P8-11	Low Bit of Running Times	0-9999	1	0	●
P8-12	Short Circuit Protection Detection Between Circuit and Ground	0: Disabled 1: Enabled	1	0	
P8-13	Not Used				
P8-14	Not Used				
P8-17	Year	2000-2100	1	2014	
P8-18	Month/Day	0101-1231	1	0101	
P8-19	Hour/Minute	00.00-23.59	0.01	00.00	
P9 Fault and Protection Parameter					
P9-09	Automatic Reset Times of Fault	0-3	1	0	
P9-11	Automatic Reset Interval Time of Fault	0.1s-100.0s	0.1s	1.0s	
P9-12	Input Phase Loss Protection	0: Disabled 1: Enabled	1	1	

A1200 Series

P9-13	Output Phase Loss Protection	1-3 Bit0: 0 Disabled during running 1 Enabled during running Bit1: 0 Disabled at start 1 Enabled at start	1	1	
P9-14	First Fault Code	0-60	1	0	●
P9-15	First Fault Subcode	0-999	1	0	●
P9-16	First Fault Month/Day	0-1231	1	0	●
P9-17	First Fault Time	00.00-23.59	0.01	0	●
P9-18	Second Fault Code	0-60	1	0	●
P9-19	Second Fault Subcode	0-999	1	0	●
P9-20	Second Fault Month/Day	0-1231	1	0	●
P9-21	Second Fault Time	00.00-23.59	0.01	0	●
P9-22	Third Fault Code	0-60	1	0	●
P9-23	Third Fault Subcode	0-999	1	0	●
P9-24	Third Fault Month/Day	0-1231	1	0	●
P9-25	Third Fault Time	00.00-23.59	0.01	0	●
P9-26	Fourth Fault Code	0-60	1	0	●
P9-27	Fourth Fault Subcode	0-999	1	0	●
P9-28	Fourth Fault Month/Day	0-1231	1	0	●
P9-29	Fourth Fault Time	00.00-23.59	0.01	0	●
P9-30	Fifth Fault Code	0-60	1	0	●
P9-31	Fifth Fault Subcode	0-999	1	0	●

A1200 Series

P9-32	Fifth Fault Month/Day	0-1231	1	0	●
P9-33	Fifth Fault Time	00.00-23.59	0.01	0	●
P9-34	Sixth Fault Code	0-60	1	0	●
P9-35	Sixth Fault Subcode	0-999	1	0	●
P9-36	Sixth Fault Month/Day	0-1231	1	0	●
P9-37	Sixth Fault Time	00.00-23.59	0.01	0	●
P9-38	Seventh Fault Code	0-60	1	0	●
P9-39	Seventh Fault Subcode	0-999	1	0	●
P9-40	Seventh Fault Month/Day	0-1231	1	0	●
P9-41	Seventh Fault Time	00.00-23.59	0.01	0	●
P9-42	Eighth Fault Code	0-60	1	0	●
P9-43	Eighth Fault Subcode	0-999	1	0	●
P9-44	Eighth Fault Month/Day	0-1231	1	0	●
P9-45	Eighth Fault Time	00.00-23.59	0.01	0	●
P9-46	Ninth Fault Code	0-60	1	0	●
P9-47	Ninth Fault Subcode	0-999	1	0	●
P9-48	Ninth Fault Month/Day	0-1231	1	0	●
P9-49	Ninth Fault Time	00.00-23.59	0.01	0	●
P9-50	Tenth Fault Code	0-60	1	0	●
P9-51	Tenth Fault Subcode	0-999	1	0	●
P9-52	Tenth Fault Month/Day	0-1231	1	0	●

A1200 Series

P9-53	Tenth Fault Time	00.00-23.59	0.01	0	●
P9-54	Last Fault Code	0-60	1	0	●
P9-55	Last Fault Subcode	0-999	1	0	●
P9-56	Last Fault Month/Day	0-1231	1	0	●
P9-57	Last Fault Time	00.00-23.59	0.01	0	●
P9-58	Last Logic Information	0-65535	1	0	●
P9-59	Last Setting Frequency	0.00Hz-99.00Hz	0.01Hz	0.00Hz	●
P9-60	Last Feedback Frequency	0.00Hz-99.00Hz	0.01Hz	0.00Hz	●
P9-61	Last Bus Voltage	0.0V-6500.0V	0.1V	0.0V	●
P9-62	Last Output Voltage	0V-6500.0V	1V	0V	●
P9-63	Last Output Current	0.00A-650.00A	0.01A	0.00A	●
P9-64	Last Torque Current	0.00A-650.00A	0.01A	0.00A	●
P9-65	Last Output Power	0.00KW-99.99KW	0.01KW	0.00KW	●
P9-66	Last Input Function Status 1	0-65535	1	0	●
P9-67	Last Input Function Status 2	0-65535	1	0	●
P9-68	Last Output Function Status 1	0-65535	1	0	●
P9-69	Last Output Function Status 2	0-65535	1	0	●
PA PG Parameter					
PA-00	PG Pulse Count	100-9999	1	1024	Ⓜ
PA-01	PG Disconnection Detection Time	0.0s-10.0s (if the time is set as 0, the detection function is disabled)	0.1s	1.0s	Ⓜ
PA-03	PG Magnetic Pole Angle	0.0-359.9	0.1	0.0	Ⓜ

A1200 Series

PA-04	Present Angle of PG Magnetic Pole	0.0-359.9	0.1	0.0	●
PA-05	Encoder Wiring Mode	0-15	1	0	Ⓜ
PA-06	PG Frequency Division Factor Ratio	1-256	1	1	Ⓜ
PB Communication Parameter (Not Used)					
PC Special Enhancement Function Parameter					
PC-00	Command Abnormality Action	0:Slow run 1: Lock output immediately	1	1	Ⓜ
PC-01	Abnormality Deceleration Time Option	0.1s-300.0s	0.1s	3.0s	Ⓜ
PC-02	Up Speed Detection Level	0.00-Maximum frequency	0.01Hz	45.00Hz	Ⓜ
PC-03	Down Speed Detection Level	0.00-Maximum frequency	0.01Hz	45.00Hz	Ⓜ
PC-04	Advance Door Opening Judgment	0.00-Maximum frequency	0.01Hz	5.00Hz	Ⓜ
PC-05	Frequency Detection Level 1	0.00-Maximum frequency	0.01Hz	50.00Hz	
PC-06	Frequency Detection Level 2	0.00-Maximum frequency	0.01Hz	50.00Hz	
PC-07	Frequency Detection Lag	0.0%-100.0% (Frequency detection level)	0.1%	5.0%	
PC-08	Frequency Reach Detection Width	0.0%-100.0%(maximum frequency)	0.1%	0.0%	
PC-09	Overspeed Judgment Level	80%-120%	1%	115%	
PC-10	Overspeed Detection Delay Time	0.0s-5.0s	0.1s	1.0s	
PC-11	Overspeed Action Options	0: Abnormal ramp-to-stop 1: Immediately send an alarm and lock output 2: Continue to run	1	1	
PC-12	Speed Deviation Judgment Level	0%-50%	1%	30%	
PC-13	Speed Deviation Detection Delay Time	0.0s-5.0s	0.1s	1.0s	
PC-14	Action at Big Speed Deviation	0: Abnormal ramp-to-stop 1: Immediately send an alarm and lock output 2: Continue to run	1	1	
PD Special Function Parameter					

A1200 Series

PD-00	Torque Boost	0.0: (Auto) 0.1%-30.00%	0.1%	1.0%	Ⓜ
PD-01	Torque Boost Frequency	0.00-Maximum frequency	0.01Hz	50.00Hz	Ⓜ
PD-02	Slip Compensation	0.0%-200.0%	0.1%	100.0%	Ⓜ
PD-03	Vibration Suppression Gain	0-100	1	20	Ⓜ
PD-04	Inverter Function 3	0-65535 Bit0: 0 Fixed current loop parameter of induction motor 1 Current loop parameter of induction motor is set by function codes	1	0	Ⓜ
PD-05	Zero Servo Current Factor	1.0%-50.0%	0.1%	15.0%	Ⓜ
PD-06	Zero Servo Speed Loop KP	0.05-1.00	0.01	0.50	Ⓜ
PD-07	Zero Servo Speed Loop T1	0.05-2.00	0.01	0.60	Ⓜ
PU Monitoring Parameter					
PU-00	Pre-torque Current	-200.0%-200.0%	0.1%	0	●
PU-01	Logic Information	0-65535	1	0	●
PU-02	Setting Frequency	0.00Hz-99.00Hz	0.01Hz	0.00Hz	●
PU-03	Feedback Frequency	0.00Hz-99.00Hz	0.01Hz	0.00Hz	●
PU-04	Bus Voltage	0.0V-6500.0V	0.1V	0.0V	●
PU-05	Output Voltage	0V-65000V	1V	0V	●
PU-06	Output Current	0.00A-650.00A	0.01A	0.00A	●
PU-07	Output Torque	0.0%-200.0%	0.1%	0.0%	●
PU-08	Torque Current	0.00A-650.00A	0.01A	0.00A	●
PU-09	Output Power	-99.99kW-99.99kW	0.01kW	0.00kW	●

A1200 Series

PU-10	Car Load	0.0%-100.0%	0.1%	0.0%	●
PU-11	Car Speed	0.000m/s-65.000m/s	0.001m/s	0.000m/s	●
PU-12	Communication Interference	0-65535	1	0	●
PU-13	Input Function Status 1	0-65535	1	0	●
PU-14	Input Function Status 2	0-65535	1	0	●
PU-15	Output Function Status 1	0-65535	1	0	●
PU-16	Output Function Status 2	0-65535	1	0	●
PU-17	AI1 Voltage	0.00V-20.00V	0.01V	0.00V	●
PU-18	AI2 Voltage	0.00V-20.00V	0.01V	0.00V	●
PU-19	AO1 Voltage	0.00V-20.00V	0.01V	0.00V	●
PU-20	Start Slip Pulse Count	0-65535	1	0	●
PU-21	Pulse Count Per Second Output By PG Card	0-65535	1	0	●
PP User Parameter					
PP-00	User Password	0-65535 0: No password	1	0	
PP-01	Parameter Update	0: None 1: Reset 2: Clear memory information	1	0	Ⓜ
PP-02	User Setting Check	0: Disabled 1: Enabled	1	0	Ⓜ

Chapter 6 Parameter Description

P0 Group: Basic Parameter

Function Code	Name	Default	Minimum Unit	Setting Range
P0-00	Control Mode	1	1	0, 1, 2

0: Sensorless Vector Control--Open Loop Vector (SVC)

This control mode is used for fault judgment during running or inspection of autotuning stage. Pay attention to that this mode is only applied to control of induction motor. Synchronous motors can only adopt closed loop control mode.

1: Feedback Vector Control---Closed Loop Vector (VC)

This control mode is applied to high accuracy speed control of the elevator. During normal operation, A1200 shall run under this control mode.

2: V/F control

This control mode is applied to special elevator application conditions. Under this mode, rotary encoder is not required but the control effect of this mode is poor compared with vector control mode.

Note: When the vector control mode is selected, it is required to conduct motor parameter autotuning. Only with correct motor parameters, advantages of vector control mode can be given into full play. Moreover, user can adjust the speed regulation parameter (P2 group) to get better performance.

Function Code	Name	Default	Minimum Unit	Setting Range
P0-01	Command Option	1	1	0, 1

Select channel of control commands of the inverter.

Control commands of the inverter include: Start and stop.

0: Keypad control (“UNIT/D.L.C” indicator on);

The start and stop of the inverter will be controlled with RUN and STOP/RES of the keypad. Moreover, the running direction can be changed by setting of P0-04.

1: Terminal control (“UNIT/D.L.C” indicator off);

Forward command (FWD) and reverse command (REV) set through multiple-function input terminals control the operation of the inverter.

◆Note: Under terminal control mode (P0-01=1), the default of control mode (P0-00) is limited as 1 and can not be changed.

Function Code	Name	Default	Minimum Unit	Setting Range
P0-02	Speed	1	1	1-5

Select the speed input channel of the inverter. There are four types of channels:

0: Digital setting

A1200 elevator inverter adopts the digital setting value inside it as the speed. The initial value is P0-03 “digital setting frequency”.

1. Preset speed

Select the preset speed running mode as the inverter running mode. P4 group “Input Function Parameter” and P6 group “Speed Parameter” are required for confirming the correspondence of setting signals and setting frequency.

2: AI1 3: AI2

Frequency is confirmed by analog input terminals. Standard A1200 elevator inverter includes two analog input terminals, of which AI1 is used as 0V-10V voltage input terminal while AI2 is used as 0V-10V voltage input and 4mA-10mA current input. Specific purpose shall be selected by jumper wire on control board.

4: Not used

5: Special preset speed

On general conditions, preset speed setting mode under special application conditions is not used.

Function Code	Name	Default	Minimum Unit	Setting Range
---------------	------	---------	--------------	---------------

A1200 Series

P0-03	Digital Setting Frequency	0.00Hz	0.01Hz	0.00Hz--Maximum frequency
-------	---------------------------	--------	--------	---------------------------

A1200 speed setting mode: Adopt the target running frequency after digital setting.

Function Code	Name	Default	Minimum Unit	Setting Range
P0-04	Running Direction	0	1	0, 1

By changing this function code, the rotary direction can be changed without changing the tractor wiring.

Note: After parameters are initialized, the motor resets to its original running direction. So please use this function code with great caution.

Function Code	Name	Default	Minimum Unit	Setting Range
P0-05	Maximum Frequency	50.00Hz	0.01Hz	0.00-90.00Hz

This function code is used to set the maximum output frequency of the inverter. Under special circumstances, when using frequency higher than power frequency, please consider the mechanical load of motors carefully.

Function Code	Name	Default	Minimum Unit	Setting Range
P0-06	Carrier Frequency	Up to specific model	0.1kHz	0.5-16.0Hz

Carrier frequency is closely related to running noises of motor. Generally, motor can run without noise when carrier frequency is set above 10kHz. You are recommended to control the inverter to run at a lower carrier frequency within the allowable noise range.

When carrier frequency is low, higher-order harmonics of output current increases, motor loss goes up and the temperature rise of motor increases.

If carrier frequency is high, the motor loss drops, motor temperature rise decreases but system loss increases, system temperature rise increases and the interference increases.

Influence of adjustment of carrier frequency on the following performance:

Carrier frequency	Low---high
Motor noise	Big--small
Output current waveform	Poor--good
Motor temperature rise	High---low
Inverter temperature rise	Low---high
Leakage current	Small---big
External radiation interference	Small---big

Function Code	Name	Default	Minimum Unit	Setting Range
P0-07	Carrier Frequency Adjustment	0	1	0, 1

0: Fixed PWM carrier frequency adjustment mode

1: Random PWM carrier frequency adjustment mode

Motor with random PWM carrier frequency adjustment mode has wide audio frequency range while the motor with fixed PWM carrier frequency adjustment mode has fixed noise frequency.

P1 Group: Motor Parameter

A1200 Series

Function Code	Name	Default	Minimum Unit	Setting Range
P1-00	Encoder Type	0	1	0, 1, 2

0: SIN/COS, absolute encoder

1: UVW encoder

2: ABZ incremental encoder

Please select appropriate parameters according to master model and set PA group PG parameter correctly.

Function Code	Name	Default	Minimum Unit	Setting Range
P1-01	Rated Power	Up to specific model	0.1kW	0.4-110.0kW
P1-02	Rated Voltage	Up to specific model	1V	100-500V
P1-03	Rated Current	Up to specific model	0.01A	0.00-655.00A
P1-04	Rated Frequency	50.00Hz	0.01Hz	0.00-90.00Hz
P1-05	Rated Rotation Speed	1460rpm	1rpm	0-3000rpm

Please set these function codes according to motor nameplate.

In order to achieve better control performance of A1200 elevator inverter, it is required to input correct motor parameters. The system has the function of parameter autotuning. For accurate parameter autotuning, it is required to set rated parameters of motor properly.

For ensuring higher control performance, please configure standard motor of the inverter. If there exists large difference between the motor power and the standard applicable motor, the control performance of the inverter will decrease significantly.

Function Code	Name	Default	Minimum Unit	Setting Range
P1-07	Power Failure Angle of Synchronous Motor	0.0	1	0.0-359.9

This function code refers to the angle of the magnetic pole of the motor upon power failure, which will be recorded at power cut and used for comparison and judgment when it is powered on again.

Function Code	Name	Default	Minimum Unit	Setting Range
P1-09	Current Filter Factor of Synchronous Motor	0.0	0.1	0.0-3.0

Setting current filter time has certain inhibition effect on periodic vertical shaking. When adjusting the filter time, increase it by 0.5 every time gradually and select the value with best effect.

Function Code	Name	Default	Minimum Unit	Setting Range
P1-10	Encoder Parity	0	1	0-65535

This function code is set by the manufacturer and please do not change it without authorization.

Function Code	Name	Default	Minimum Unit	Setting Range
P1-11	Motor autotuning	0	1	0-4

1) Select autotuning mode and optional values include:

0: No operation;

1: Autotuning for a motor with load: Induction motor adopts stationary autotuning, while synchronous motor adopts rotary autotuning mode;

2: Autotuning for a motor with no load;

2) Attentions for autotuning:

- Please make sure all installation and wiring meet safety technical specifications.
- When adopting autotuning for a motor with load, ensure the motor is properly wired (motor UVW corresponds to controller UVW one by one). If the motor is wired improperly, the motor may shake back and forth or doesn't work after the brake is turned on. At this time, it is required to exchange any two phases of UVW motor cables.

- Under the fault alarm status, the system can not be autotuned (TUNE is not displayed). Please reset current fault and start autotuning.

- For synchronous master, please tune the motor again when motor wiring sequence is changed or encoder is replaced.

- For synchronous master, please autotune the motor for multiple times (more than three times) and compare the PG initial angle (PA-03). If the error is within 5° , autotuning is completed successfully.

- After autotuning is completed, conduct commissioning at low speed to observe if current is normal; if the actual running direction is consistent with the setting direction. In case of inconsistency, please change it through P0-04.

- The autotuning process for a motor with load can be dangerous (slow run set in many control cabinets can be motor-operated emergency running. Safety circuit of hoistway is short-circuited. Attentions must be paid to this), so please ensure that there is no person in hoistway during autotuning.

Motor parameter autotuning process is as follows:

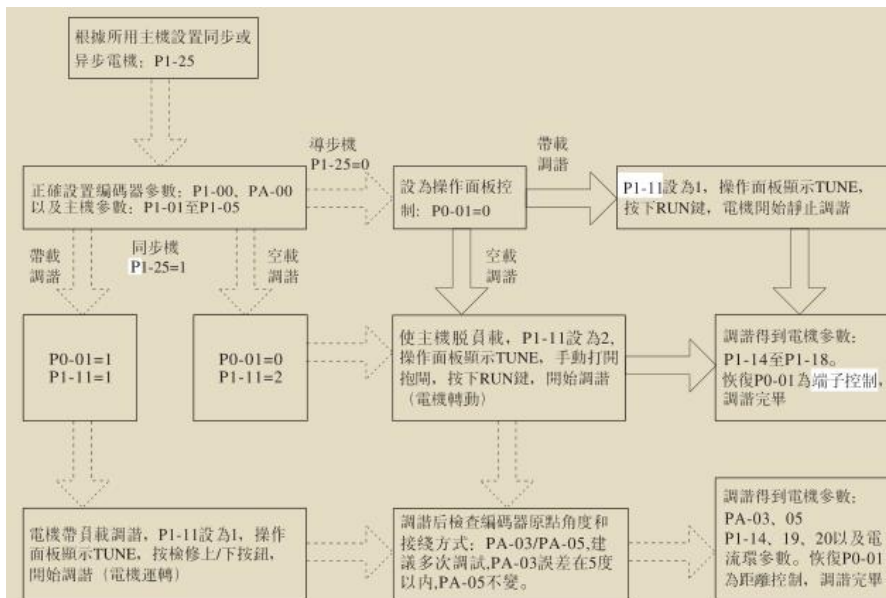

Set synchronous motor or induction motor according to the master used: P1-25

Set encoder parameters properly: P1-00, PA-00 and master parameters: P1-01 to	Guiding machine P1-25=0	Set as operation panel control: P0-01=0	Autotuning for a motor with load	If P1-11 is set as 1, TUNE is displayed on operation panel. By pressing RUN, motor
---	----------------------------	--	----------------------------------	--

P1-05				starts to conduct stationary autotuning
Autotuning for a motor with load	Synchronous motor P1-25=1	Autotuning for a motor with no load	Autotuning for a motor with no load	
P0-01=1 P1-11=1	P0-01=0 P1-11=2	Remove the motor load and set P1-11 as 2. Then TUNE is displayed on operation panel. Manually open the brake and press down RUN to start autotuning (motor runs)	Motor parameters acquired by autotuning: P1-14 to P1-18 Reset P0-01 as terminal control and then autotuning is completed.	
Under autotuning for a motor with load, P1-11 is set as 1 and TUNE is displayed on operation panel. Then pressing the Inspection Up/Down button to start autotuning (motor runs)		After autotuning, check the original point angle and wiring modes of encoders: PA-03/PA-05. Repeated autotuning is recommended. When the error of PA-03 is within 5°, PA-05 remains unchanged.	Motor parameters acquired by autotuning: PA-03, 05, P1-14, 19, 20 and current loop parameters. Reset P0-01 as distance control mode and then autotuning is completed.	

Figure 6-1 Motor Autotuning Procedure

Description of autotuning of synchronous motor:

- As A1200 synchronous motor system requires feedback signal of encoder, it is required to set encoder parameters properly before autotuning;
- The motor must rotate during the autotuning of synchronous motor system. The best autotuning mode is idling dynamic autotuning. If conditions do not permit, on-load dynamic autotuning mode can be adopted;
- On-load autotuning of synchronous motor includes autotuning of stator resistor, D and Q shaft inductance, current loop(zero servo inclusive) PI parameter, zero position angle of encoder; during idling autotuning, the system will autotune the encoder wiring modes;
- Stator resistor, rotor resistor, leakage inductance, mutual inductance and idling current will be autotuned during the stationary autotuning process of induction motor; complete autotuning includes autotuning of mutual inductance, idling current and current loop parameters.

3) List of running brake output control

As the safety of control system is different under different statuses, the system adopts different modes to process running and brake contactor output under different statuses. In some cases, it is required to turn on the running or brake contactor manually. Relevant statuses are listed as follows:

Table 6-1 List of Output Status

Output status Control mode	Idling autotuning	On-load autotuning		Panel control P0-01=0	Terminal control P0-01=1
		Synchronous motor	Induction motor		
Running contactor	Output	Output	Output	No output	Output
Brake contactor	No output	Output	No output	No output	Output

Function Code	Name	Default	Minimum Unit	Setting Range
---------------	------	---------	--------------	---------------

A1200 Series

P1-14	Stator Resistor	Up to specific model	0.001 Ω	0.001-65.000 Ω
P1-15	Rotor Resistor of Induction Motor	Up to specific model	0.001 Ω	0.001-65.000 Ω
P1-16	Leakage Inductance of Induction Motor	Up to specific model	0.01mH	0.01-650.00mH
P1-17	Mutual Inductance of Induction Motor	Up to specific model	0.1mH	0.1-6500.0mH
P1-18	Idling Current of Induction Motor	Up to specific model	0.01A	0.01-650.00A
P1-19	D-shaft Inductance of Synchronous Motor	0.01mH	0.01mH	0.01-650.00mH
P1-20	Q-shaft Inductance of Synchronous Motor	0.01mH	0.01mH	0.01-650.00mH
P1-21	Back Electromotive Force of Synchronous Motor	0V	1V	0-65535V
P1-25	Motor Type	1	1	0: Induction motor 1: Synchronous motor

For ensuring control performance, please configure standard motor for the inverter. If there exists large difference between the motor power and standard applicable motor, the control performance of the inverter will be significantly decreased.

After motor autotuning is completed normally, P1-14 - P1-21 will be updated automatically.

In terms of induction motor, if it is impossible to autotune the motor due to field conditions, user can manually input parameters by reference to parameters of motors with same nameplate parameters.

◆ Remarks: Every time after the motor rated power P1-01 of induction motor is changed, the system will restore P1-14-P1-18 to the default standard motor parameter automatically.

P2 Group: Vector Control Parameter

Function Code	Name	Default	Minimum Unit	Setting Range
P2-00	Speed Loop Proportional Gain 1	35	1	0-100

P2-01	Speed Loop Integral Time 1	0.60s	0.01s	0.01-10.00s
P2-02	Switching Frequency 1	2.00Hz	0.01Hz	0.00-P2-05
P2-03	Speed Loop Proportional Gain 2	30	1	0-100
P2-04	Speed Loop Integral Time 2	0.80s	0.01s	0.01-10.00s
P2-05	Switching Frequency 2	5.00Hz	0.01Hz	P2-02- Maximum frequency

P2-00 --P2-05 are used for autotuning speed loop performance during open and closed-loop vector control.

P2-00 and P2-01 are PI regulation parameters when the running frequency is less than the switching frequency 1(P2-02); P2-03 and P2-04 refer to PI regulation parameter when the running frequency is greater than the switching frequency 2 (P2-05). PI regulation parameter between the switching frequency 1 and the switching frequency 2 is the weighted average value of P2-00, P2-01 and P2-03 as well as P2-04, as shown in the figure below:

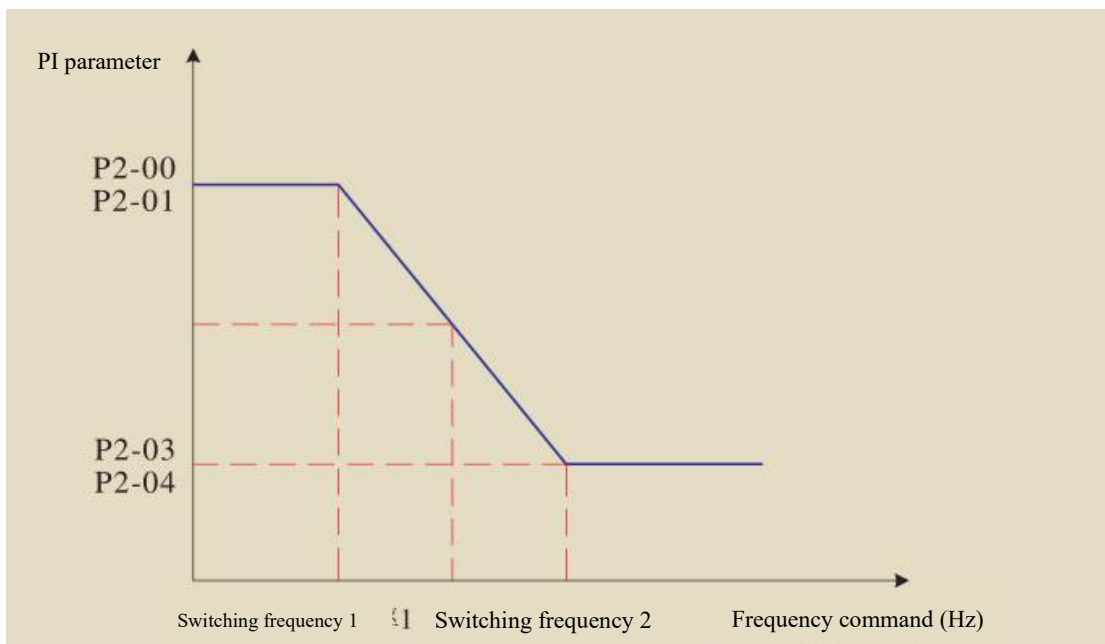

Figure 6-2 Parameters Schematic Diagram

The inverter adjusts the dynamic speed response under vector control mode by adjusting the speed proportional gain and speed integral time of regulator. Either increasing the speed proportional gain or reducing speed integral time would quicken the dynamic response of the speed loop. However, if the speed proportional gain is excessive or the speed integral time is insufficient, this will result in oscillation.

Proposed regulation method:

The default can be applied to almost all situations. If the default can not meet requirements (especially when the inverter runs by motor with small power), the speed loop default proportional

gain may be slightly larger and there exists oscillation of motor upon start. At this time, user shall reduce the speed loop proportional gain to ensure no system oscillation. Then user shall increase the proportional gain as possible and regulate the integral time so as to enable the system to response quickly without over control.

If the switching frequency 1 and switching frequency 2 are 0 at the same time, only P2-03 and P2-04 are valid.

◆ Note: If PI is set improperly, it may result in speed over regulation and even result in overvoltage when over-control backs to original status.

Function Code	Name	Default	Minimum Unit	Setting Range
P2-06	Current Loop Proportional Gain	60	1	10-500
P2-07	Current Loop Integral Gain	30	1	10-500

Under the vector control mode, P2-06 and P2-07 are current loop regulation parameters. Generally, users do not need to adjust this parameter and the default parameter can achieve the control performance of vector control mode. If regulation is required, please refer to the regulation method of speed loop PI.

Function Code	Name	Default	Minimum Unit	Setting Range
P2-08	Upper Limit of Torque	150.0%	0.1%	0.0-200.0%

This function code refers to the limit of A1200 output torque current. During start of the elevator, the upper limit of pre-torque compensation used also adopts function parameter. When this function parameter is set as 100%, it corresponds to the rated output torque of system applicable motor.

Function Code	Name	Default	Minimum Unit	Setting Range
P2-09	Torque Acceleration Time	1ms	1ms	1-500ms
P2-10	Torque Deceleration Time	350ms	1ms	1-500ms

These two function codes are used to set the acceleration and deceleration time of the torque.

During stop process, as the characteristics of the master are different, the master may send a “chocking sound” when current is removed. At this time, user can increase the torque deceleration time properly to eliminate the abnormal sound.

Function Code	Name	Default	Minimum Unit	Setting Range
P2-11	Speed Filter Factor	10	1	1-20

This function code is used to eliminate speed feedback fluctuation and requires no need generally.

Function Code	Name	Default	Minimum Unit	Setting Range
P2-12	Autotuning Function	0	1	0-65535

It is used for setting relevant options of autotuning function.

P2-12 Autotuning Function			
Bit	Function Definition	Definition	Default
Bit1	Autotuning Enable	0: Disabled 1: Enabled	0
Bit2	Notes 1 of Autotuning Mode	0: Semi-automatic 1: Full-automatic	0

◆ Note: Semi-automatic mode refers to that the autotuning function enabled only when inspection signal is enabled. Full-automatic mode refers to that the autotuning function will be enabled whether the inspection signal is enabled or disabled.

P3 Group: VF Function Parameter

Function Code	Name	Default	Minimum Unit	Setting Range
P3-00	Start Frequency	0.00Hz	0.01Hz	0.00-10.00Hz

In order to improve the start torque of the elevator, set an appropriate start frequency. Moreover, In order to enable the motor to make magnetic flux fully, it's required to maintain the motor's start frequency for certain time. When A1200 elevator inverter is in the preset speed control mode, this function works; under the digital setting, analog setting and other modes, setting of this start frequency is disabled.

Function Code	Name	Default	Minimum Unit	Setting Range
P3-01	Torque Output Delay	0.20s	0.01s	0.00-10.00s
P3-02	Brake Open Delay	0.20s	0.01s	0.20-10.00s
P3-03	Zero Speed Delay	0.30s	0.01s	0.00-10.00s
P3-04	Start Time	0.00s	0.01s	0.00-10.00s
P3-05	Start Frequency Holding Time	0.00s	0.01s	0.00-10.00s
P3-06	Brake Release Delay	0.20s	0.01s	0.00-10.00s
P3-07	Stop Release Delay	0.30s	0.01s	0.00-10.00s
P3-08	Running Contactor Release Delay	0.00s	0.01s	0.00-10.00s

By setting function code P3-01 --P3-08, the easiness of elevator during start and stop can be adjusted properly. Please see figure below for specific definition of all function codes (Example: running at preset speed):

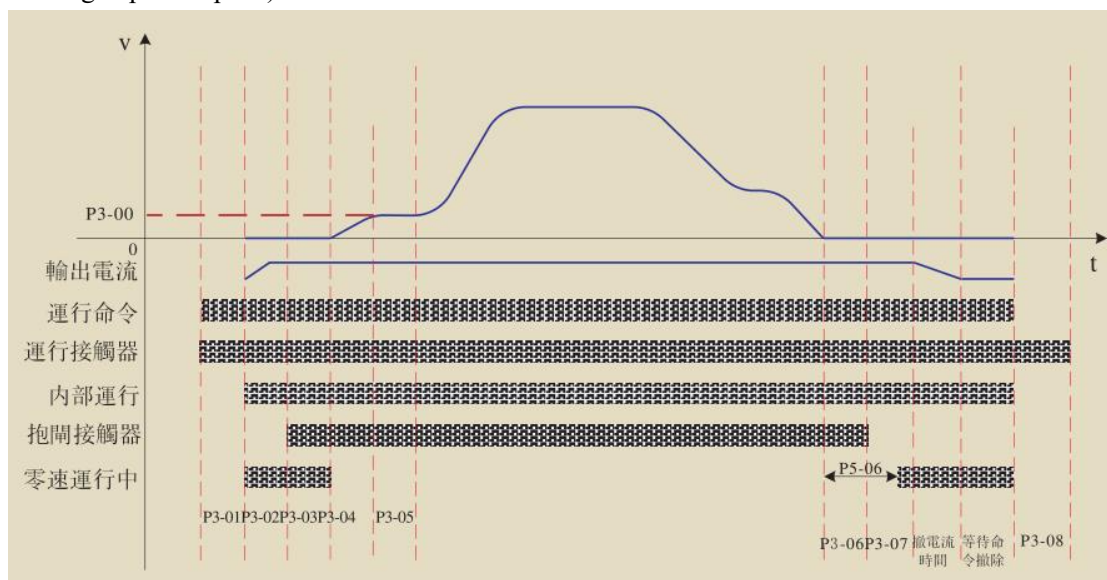

输出电流: Output current

运行命令: Running command

运行接触器: Running contactor

内部运行: Internal running

抱闸接触器: Brake contactor

零速运行中: Zero Speed Running

撤电流时间: Current removal time 等待命令撤

除: Waiting for the command of removal

Figure 6-3 Running Sequence

The time of current removal depends on actual current and torque deceleration time (P2-10).

The waiting time for commands of removal can be set as waiting all the time or waiting for 5s at most. See the description of P6-23 for detail.

When the running contactor output control function of A1200 is disabled, directly skip the time period of P3-01 and P3-08.

When the brake output control and running output function of A1200 are disabled, directly skip the time period of P3-02 and P3-07.

Function Code	Name	Default	Minimum Unit	Setting Range
P3-09	Start Pre-torque Setting	0	1	0-5

Setting Value	Description
0	No pre-torque
1	DI setting
2	AI1 setting
3	AI2 setting
4	Fixed pre-torque
5	no-weighing compensation

A1200 inveter has five pre-torque setting options of which DI setting, AI1 setting and AI2 setting can only be enabled with weighing sensor. When the pre-torque compensation function enabled, the system can output the torque applicable to elevator load in advance to ensure the instant comfort of elevator when the brake is opened. The output pre-torque is subject to the upper limit of torque (P2-08). When the pre-torque calculated is greater than P2-08, the system output torque is the upper limit of torque P2-08.

During application, if the elevator has no sensor, operators can set P3-09 as 4 and then regulate the pre-torque offset of P3-12 so as to enable A1200 can conduct pre-excitation fully before the brake is turned on, which will improve the comfort at start. However, this parameter can not be set excessive and shall be set between -15% --15%.

If sensorless compensation function is enabled and P3-09=5, debug PD-05 PD-07 according to field conditions and adjust them gradually based on PD-05=15.0%, PD-07=0.50 and PD-08=0.60.

Function Code	Name	Default	Minimum Unit	Setting Range
P3-10	Pre-torque Shift	48.0%	0.1%	0.0-100.0%
P3-11	Pre-torque Gain	0.60	0.01	0.00-1.50

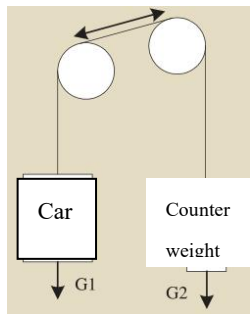

Figure 6-4 Car Counterweight Relationship

Pre-torque shift, i.e., the balance coefficient of the elevator, refers to the percentage of the counterweight relative to the rated load of the elevator. If the elevator's load is G_1 , the weight of counterweight is G_2 and the rated load of elevator is G_3 during idling, the pre-torque shift $(P3-10)=(G_2-G_1)/G_3$.

If the material weight in the car is G_4 , the pre-torque output of motor is:
 Pre-torque output of motor=pre-torque gain */ $G_4-(G_3*(P3-10))$ /

The output pre-torque direction has nothing to do with the running direction, and is only relative to the car load;
 If the car load is greater than $(G_3*(P3-10))$, the output pre-torque goes upward, otherwise, it goes downward.

Function Code	Name	Default	Minimum Unit	Setting Range
P3-12	Initial Offset of Pre-torque	10.0%	0.1%	-100.0-100.0%

When P3-09 is set as 4 (fixed pre-torque), before opening the brake, A1200 will output corresponding pre-torque current based on P3-12 to conduct pre-exaction so as to improve the start comfort. But this parameter shall not be set as too large, and shall be set between -15%-15%.

Function Code	Name	Default	Minimum Unit	Setting Range
P3-13	DI Weighing Signal 1	10.0%	0.1%	0.0-100.0%
P3-14	DI Weighing Signal 2	30.0%	0.1%	0.0-100.0%
P3-15	DI Weighing Signal 3	70.0%	0.1%	0.0-100.0%
P3-16	DI Weighing Signal 4	90.0%	0.1%	0.01-00.0%

When P3-09 is set as 1, A1200 will detect the car load according to the four DI weighing signals and then control the pre-torque current output.

Four setting values of P3-13--P3-16 shall correspond to the weighing terminal 1 to 4 one by one and shall be used cooperatively. The setting value of each function code refers to the percentage of corresponding car load when this signal is enabled.

For example, when the car load reaches to 10%, the weighing terminal 1 signal is enabled and then P3-13 is set as 10%; when the car load reaches to 30%, the signal of weighing terminal 2 is enabled and then P3-14 is set as 30%.

Function Code	Name	Default	Minimum Unit	Setting Range
P3-17	Weighing Analog Input Filter Time	0.10s	0.01s	0.00-1.00s
P3-18	Corresponding Input of Weighing Analog Idling	0.00V	0.01V	0.00-10.00V
P3-19	Corresponding Input of Weighing Analog Full-load	10.00V	0.01V	0.00-10.00V

When P3-09 is set as 2 or 3, A1200 will detect the car load according to AI1 or AI2 analog signal and then control the pre-torque current.

P3-19 refers to the filter time of analog signal. Generally, increasing this parameter properly can effectively improve the anti-interference performance of weighing signals.

When analog weighing signal input mode is adopted, the analog input voltage when the car is idling and full must be set properly so as to ensure correct pre-torque compensation.

The functional block diagram of pre-torque as follows:

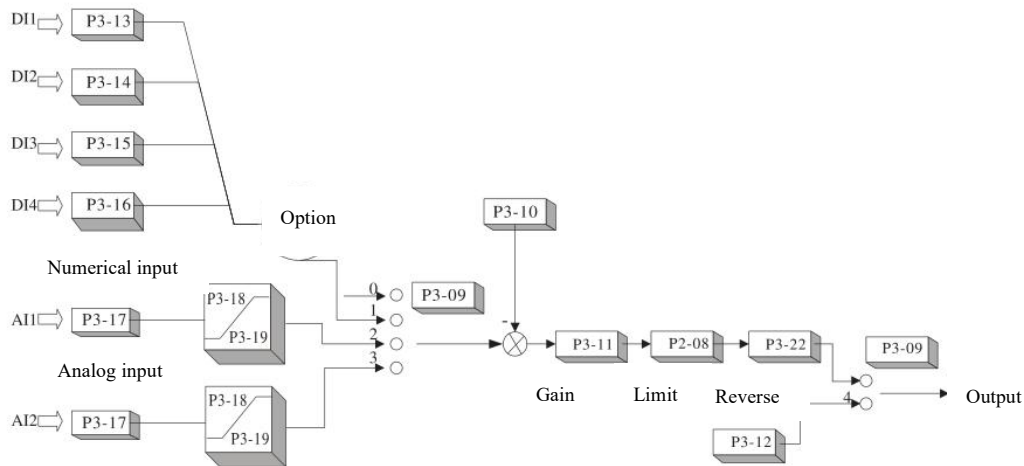

Figure 6-5 Principal Block Diagram of Pre-torque

Function Code	Name	Default	Minimum Unit	Setting Range
P3-20	Analog Weighing Autotuning	0	1	0-100
P3-21	Analog Weighing Autotuning Options	0	1	0, 1

When analog weighing autotuning mode is selected, the inverter can autotune the weighing, and that is to record idling and full-load data into P3-18 and P3-19 through variation of car load. Specific operation is as follows:

- 1) Make sure to set P3-2 1 as 1 and P3-09 as 2 or 3 so as to enable autotuning of the system.
- 2) Make the elevator stay at any floor and the car in idling status, then input the setting value of P3-20 as 0 and press ENTER to input the value.
- 3) Place N% loads in the car, set P3-20=N and press ENTER to enter the parameter. For example: When placing 100kg material in the elevator with rated capacity of 1000kg, input P3-20=10. The autotuning of weighing is completed.

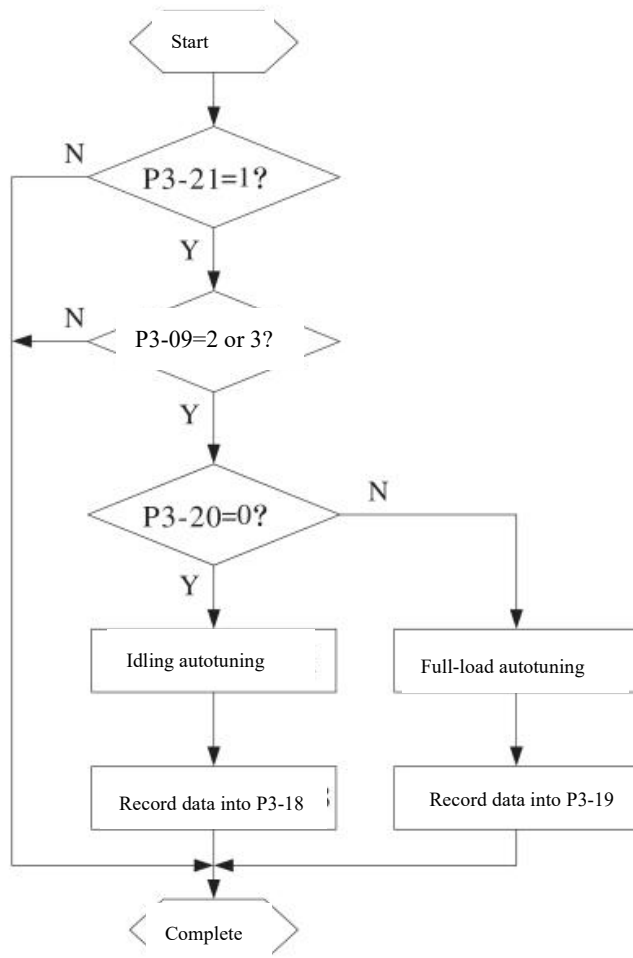

Figure 6-6 Autotuning Procedure of Analog Weighing

Note:

- ◆ During autotuning , P3-21 is set as 1. After autotuning is completed, please reset P3-21 as 0.
- ◆ Be sure to conduct idling autotuning firstly before conducting full-load autotuning , otherwise the data acquired may be incorrect.

Function Code	Name	Default	Minimum Unit	Setting Range
P3-22	Pre-torque Direction Reverse	0	1	0, 1

Through this function code, operators can reverse the direction without changing the pre-torque value.

Function Code	Name	default	Minimum Unit	Setting Range
P3-24	Slip Test Function	0	1	0-65535

In order to conduct slipping test, a inspection signal input point must be set and the inspection signal enabled.

Specific operating procedures:

- 1) Set P3-24=1 at stop status;
- 2) Enable the inspection input signal of A1200 elevator inverter;
- 3) Press down the inspection running button to conduct an overhaul.

Under the slipping test mode, the inverter will accelerate according to the acceleration time set by P7-16. If the slipping effect is not obvious, P7-16 can be decreased appropriately.

A1200 Series

After slipping test is completed, change P3-24 as 0 to make the inverter exit the slipping test mode.

P4 Group: Input Function Parameter

Function Code	Name	Default	Minimum Unit	Setting Range
P4-00	Input Filter Time	0.020s	0.001s	0.001-0.200s

This function code is used to set the sensitivity of terminals. If digital terminals are susceptible to interference, which may result in incorrect actions, increase this parameter and then the anti-interference performance will be improved but the sensitivity of input terminals is reduced.

Function Code	Name	Default	Minimum Unit	Setting Range
P4-01	DI1 Terminal Function	1	1	0-122
P4-02	DI2 Terminal Function	2	1	0-122
P4-03	DI3 Terminal Function	3	1	0-122
P4-04	DI4 Terminal Function	4	1	0-122
P4-05	DI5 Terminal Function	5	1	0-122
P4-06	DI6 Terminal Function	6	1	0-122
P4-07	DI7 Terminal Function	7	1	0-122
P4-08	DI8 Terminal Function	0	1	0-122
P4-09	DI9 Terminal Function	0	1	0-122
P4-10	DI10 Terminal Function	0	1	0-122

These parameters are used for setting functions of digital multi-function terminals and specific functions are described below:

Setting value	Function	Description															
0	No function	The inverter has no action even there exists signal input. Disable functions of terminals not used to avoid incorrect actions.															
1	Forward command (FWD)	Control the forward and reverse of the inverter through external terminals, which in turn enable the elevator to go up and down. Attentions: Every time after conclusion of running, command terminal will be disconnected once. Otherwise, the elevator can not start running again. <table border="1" style="margin-left: auto; margin-right: auto;"> <thead> <tr> <th>FWD</th> <th>REV</th> <th>Definition</th> </tr> </thead> <tbody> <tr> <td>OFF</td> <td>OFF</td> <td>Disabled</td> </tr> <tr> <td>ON</td> <td>OFF</td> <td>Forward</td> </tr> <tr> <td>OFF</td> <td>ON</td> <td>Reverse</td> </tr> <tr> <td>ON</td> <td>ON</td> <td>Disabled</td> </tr> </tbody> </table>	FWD	REV	Definition	OFF	OFF	Disabled	ON	OFF	Forward	OFF	ON	Reverse	ON	ON	Disabled
FWD	REV	Definition															
OFF	OFF	Disabled															
ON	OFF	Forward															
OFF	ON	Reverse															
ON	ON	Disabled															
3	Preset speed terminal 1 (K1)	Through combination of digital statuses of three terminals, the system can set the speed of eight sections. Detailed combination is shown below:															
4	Preset speed terminal 2(K2)																
5	Preset speed																
		<table border="1" style="width: 100%;"> <thead> <tr> <th>K3</th> <th>K2</th> <th>K1</th> <th>Frequency Setting</th> <th>Corresponding Parameter</th> </tr> </thead> <tbody> <tr> <td> </td> <td> </td> <td> </td> <td> </td> <td> </td> </tr> </tbody> </table>	K3	K2	K1	Frequency Setting	Corresponding Parameter										
K3	K2	K1	Frequency Setting	Corresponding Parameter													

A1200 Series

	terminal 3(K3)	OFF	OFF	OFF	Preset speed 0	P6-00
		OFF	OFF	ON	Preset speed 1	P6-01
		OFF	ON	OFF	Preset speed 2	P6-02
		OFF	ON	ON	Preset speed 3	P6-03
		ON	OFF	OFF	Preset speed 4	P6-04
		ON	OFF	ON	Preset speed 5	P6-05
		ON	ON	OFF	Preset speed 6	P6-06
		ON	ON	ON	Preset speed 7	P6-07
6	Fault Reset input	External fault reset function. Same as the button RESET in function. With this function, elevator fault can be automatically reset.				
7	Enable control input	The inverter is set with running enable terminal. If the enable signal disappears during the running, the inverter will stop and output brake closure command immediately.				
8	Inspection input	When inspection input is enabled, A1200 will select the preset speed by non-zero parameters. During stop, if the inspection input signals are removed firstly, A1200 will decelerate to 0 according to the preset speed deceleration time set in P6-16 until the forward or reverse commands are canceled; if the forward or reverse commands are directly canceled during inspection running process, A1200 will stop immediately.				
9	Emergency input	In case of emergency input, the elevator will enter the emergency running status with external 48V battery supply or 220V UPS power supply.				
10	Running contactor feedback input	If the contactor feedback signal terminals or brake feedback signal terminals are set, the inverter will start to detect the contactor feedback signals and brake feedback signals after shut down (after disconnection signal of the output contactor). If these two feedback signals still exist, and last for 2.5s, A1200 will output the message that “adhesion signal” enabled. If contactor feedback signal is selected, detect this signal during start of A1200 elevator inverter. If brake feedback signal is selected, detect this signal				
11	Brake feedback input					

A1200 Series

		during running of A1200 elevator inverter.
12	Weighing terminal 1 input	Weighing signals of corresponding digital values. Relevant setting parameters are included between P3-13 --P3-16.
13	Weighing terminal 2 input	
14	Weighing terminal 3 input	
15	Weighing terminal 4 input	
16	External fault input	External fault input point. When this signal is enabled, the system will send an alarm and stop running.
17	Motor overheating input	After DI terminal is set as 17 or 117 (NO/NC input of motor overheating) and when corresponding digital terminal signals are enabled, it is judged as motor overheating protection. When the digital signal is disabled, motor overheating fault will be reset automatically.
18	Up speed judgment input	Through these two signal functions and PC-02 and PC-03, forced deceleration function can be realized. When the elevator goes up, if the up speed judgment switch(forced deceleration switch) has action, A1200 will compare current running frequency with PC-02. If it is greater than PC-02, A1200 will slow down and stop immediately (according to time setting of PC-01) to ensure elevator safety. This is also same when the elevator goes down. See description of PC Group for detail.
19	Down speed judgment input	
20	Preset speed logic 1	Preset speed setting mode(P0-02=5) for special application. Never use this option during common application situation.
21	Preset speed logic 2	
22	Direct stop command	This signal directly enable the direct stop function. During the ramp-to-stop status, A1200 will directly stop when this signal is enabled. Please see Section 7.7 for detail.

◆Note: Terminal input range: 0-122; if the hundreds place is 1, it refers to this signal is normally closed and effective. If the hundreds place is 0, this signal is normally open and effective; the low two bits refer to terminal input functions. When the value is greater than 22, this function is disabled; for example: 106 refers to the terminal is used for fault reset and the signal is normally closed.

Function Code	Name	Default	Minimum Unit	Setting Range
P4-13	Preset Speed Filter Time	0.020s	0.001s	0.000-0.200s

During use of the elevator, this command is set by external controller. Incorrect setting of preset speed command caused by relay delay or dispersion of controller terminals may result in abnormality of running curve of the elevator.

Filter preset speed terminals through P4-13 to remove wrong commands in the switching process

of preset speed. As shown below:

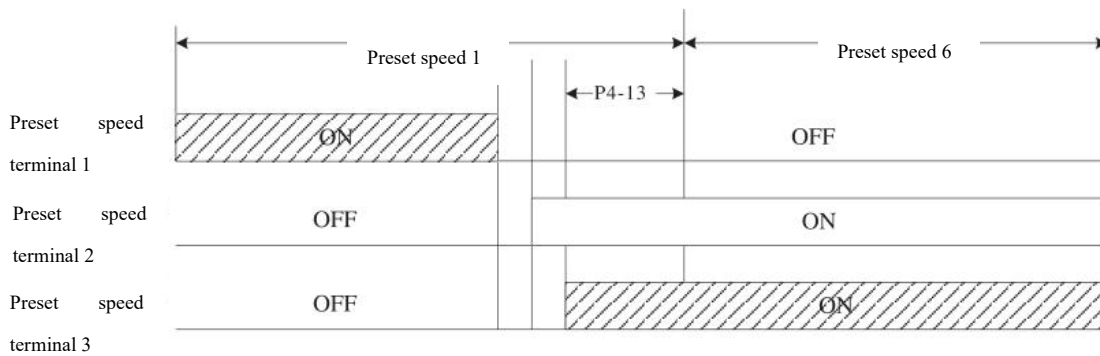

Figure 6-7 Preset Speed Signal Switching Procedure

P5 Group: Output Function Parameter

Function Code	Name	Default	Minimum Unit	Setting Range
P5-00	Not Used	15	1	0-18
P5-01	TA3-TC3Output	6	1	0-18
P5-02	TA4-TC4 Output	5	1	0-18
P5-03	TA1-TB1-TC1 Output	4	1	1-18
P5-04	TA2-TB2-TC2 Output	1	1	0-18

All functions are described as follows:

Setting value	Function	Description
0	No output	Output terminals have no function
1	Running	The inverter is running and ON signal is output at this time
2	Zero speed running	This signal enabled when the inverter runs at zero speed.
3	Zero speed signal	This signal enabled when the output frequency of the inverter is 0 or during stop,
4	Fault signal	The fault signal enabled in case of inverter fault.
5	Running contactor output function	Action of running contactor under output control.
6	Brake output control	Action of brake contactor under output control.
7	Advance door-opening signal	Under the ramp-to stop mode, if the output frequency is lower than PC-04 setting, this signal enabled.
8	Bus undervoltage	When the bus voltage is less than 280V, the inverter will output the bus undervoltage signal for realizing elevator running by battery supply.
9	FDT 1 output	Please refer to description of PC parameter group.
10	FDT 2 output	
11	Frequency reach	

A1200 Series

12	Overspeed output	When the running frequency of the inverter exceeds the setting value (PC-09) and the overspeed time exceeds PC-10, the inverter will output overspeed signal.
14	Running time reach	The accumulated running time of the inverter exceeds the time set by P8-07, the inverter will output ON signal.
15	Running ready	The inverter is ready for running and it outputs ON signal.
16	Contact adhesion output control	When contactor adhesion status is detected, the inverter will output ON signal
17	Releveling output	The inverter is ready for running and the running frequency is less than PC-05 setting, then the inverter outputs ON signal.
18	Light-load running output	During light-load running, the inverter outputs ON signal

Function Code	Name	Default	Minimum Unit	Setting Range
P5-06	Zero Speed Output Lag Time	0.000s	0.001s	0.000-2.000s

When output function 2(Zero Speed Running) is selected, the lag time of this output signal is determined by P5-06. See figure 6-3 for corresponding relation.

Function Code	Name	Default	Minimum Unit	Setting Range
P5-07	AO Output	0	1	0-6

The master control panel of A1200 elevator inverter has an analog output terminal and P5-07 describes function of this analog output terminal.

Standard analog output (zero offset: 0, gain: 1): 0mA-20mA(or 0V-10V). The range of relative value is described in the table below:

Setting value	Function	Description
0	Running frequency	0-Maximum output frequency
1	Setting frequency	0-Maximum output frequency
2	Output current	0-2 times of the rated current of the inverter
3	Output torque	0-2 times of the rated current of the motor
4	Output voltage	0-1.2 times of the rated voltage of the inverter
5	AI1	0V-10V
6	AI2	0V-10V/0mA-20mA

Function Code	Name	Default	Minimum Unit	Setting Range
P5-08	AO Zero Offset Factor	0.0%	0.1%	-100.0-100.0%
P5-09	AO Gain	1.00	0.01	-10.00-10.00

If use “b” for offset, “k” for gain, “Y” for actual output, and “X” for standard output, then the actual output is: $Y=kX + b$.

$$Y=kx+b;$$

AO offset factor 100% corresponds to 10V(20mA).

A1200 Series

Standard output refers to 0V-10V output (20mA). Corresponding analog output: 0- Maximum frequency.

These function codes are generally used to correct the zero shift and output amplitude deviation of the analog output, and they can be also used to define the desired output curves.

For example: if the analog output is running frequency, and 8V(16mA) is required to be output when the frequency is 0 and 3V(6mA) is output under the maximum frequency, then the gain shall be set as “-0.50” and the zero offset shall be set as “80%”.

◆ Note: When the Direct Stop Function is enabled, AO output function will be disabled automatically.

P6 Group: Speed Parameter

When A1200 selects preset speed running mode, it is required to set parameters P6-00 --P6-15 to determine the running characteristics of its curves.

Function Code	Name	Default	Minimum Unit	Setting Range
P6-00	Preset Speed 0	0.00Hz	0.01Hz	0.00-Maximum frequency
P6-01	Preset Speed 1	0.00Hz	0.01Hz	0.00-Maximum frequency
P6-02	Preset Speed 2	0.00Hz	0.01Hz	0.00-Maximum frequency
P6-03	Preset Speed 3	0.00Hz	0.01Hz	0.00-Maximum frequency
P6-04	Preset Speed 4	0.00Hz	0.01Hz	0.00-Maximum frequency
P6-05	Preset Speed 5	0.00Hz	0.01Hz	0.00-Maximum frequency
P6-06	Preset Speed 6	0.00Hz	0.01Hz	0.00-Maximum frequency
P6-07	Preset Speed 7	0.00Hz	0.01Hz	0.00-Maximum frequency

Eight different speeds can be set through three numerical input terminals(preset speed terminals 1-3). At this time, P0-02 is set as 1, numerical input terminals selected are defined as 3, 4 and 5 orderly and represented by K1, K2 and K3.

The following table describes the relationship between numerical input terminal and corresponding speed:

K3	K2	K1	Frequency Setting	Corresponding Parameter
OFF	OFF	OFF	Preset Speed 0	P6-00
OFF	OFF	ON	Preset Speed 1	P6-01
OFF	ON	OFF	Preset Speed 2	P6-02
OFF	ON	ON	Preset Speed 3	P6-03
ON	OFF	OFF	Preset Speed 4	P6-04

A1200 Series

ON	OFF	ON	Preset Speed 5	P6-05
ON	ON	OFF	Preset Speed 6	P6-06
ON	ON	ON	Preset Speed 7	P6-07

A1200 elevator inverter can select the present target running frequency through preset speeds commands. For example, when preset speed 2 is selected, A1200 elevator inverter will take P6-02 parameter as the present target running frequency of inverter. Therefore, during running of the elevator, the master controller of the system will select and input different preset speeds into A1200 elevator inverter according to conditions, thus realizing control on elevator running speed.

Function Code	Name	Default	Minimum Unit	Setting Range
P6-08	Preset Speed 0 Acceleration/Deceleration Curve	1	1	1-4
P6-09	Preset Speed 1 Acceleration/Deceleration Curve	1	1	1-4
P6-10	Preset Speed 2 Acceleration/Deceleration Curve	1	1	1-4
P6-11	Preset Speed 3 Acceleration/Deceleration Curve	1	1	1-4
P6-12	Preset Speed 4 Acceleration/Deceleration Curve	1	1	1-4
P6-13	Preset Speed 5 Acceleration/Deceleration Curve	1	1	1-4
P6-14	Preset Speed 6 Acceleration/Deceleration Curve	1	1	1-4
P6-15	Preset Speed 7 Acceleration/Deceleration Curve	1	1	1-4

A1200 offers four groups of acceleration/deceleration time. See description of P7 Group for detail. Function codes P6-08 --P6-15 can be used to set the acceleration/deceleration time of each preset speed, i.e., 1-4. So that different curves have different acceleration/deceleration time when the elevator runs in different statuses.

Special Note: Under acceleration mode, adopt the acceleration time of target speed and the S curve setting of this acceleration time; under deceleration mode, adopt the deceleration time of starting speed and the S curve setting of this deceleration time.

For example: P6-01=0.00Hz; P6-03=8.00Hz; P6-05=48.00Hz; P6-09=2; P6-11=3; P6-13=4.

When the speed is accelerated from P6-01 to P6-05, the acceleration time adopted is the acceleration time 4 selected by P6-13 (P7-12);

When the speed is decelerated from P6-05 to P6-3, the deceleration time adopted is the

deceleration time 4 selected by P6-13(P7-13);

When the speed is decelerated from P6-03 to P6-01, the deceleration time adopted is the deceleration time 3 selected by P6-11(P7-09).

This is a complete running process when the elevator is under preset speeds control mode. During this process, high-speed acceleration time and deceleration time are generally set as 3-4s. However, during the deceleration process from crawling to zero speed, the deceleration time parameter may be different from normal deceleration time. In such example, increase P7-05 properly can ensure smooth transition of speed during stop process. See figure 6-8:

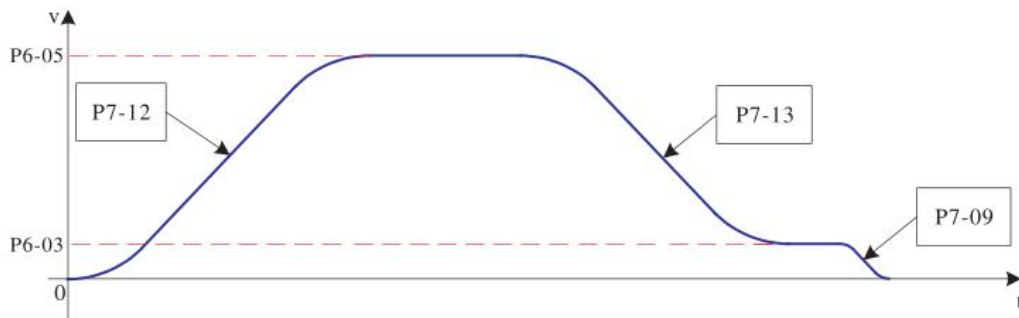

Figure 6-8 Acceleration/Deceleration Time

A1200 elevator inverter can form different acceleration/deceleration curves through eight preset speeds and four time parameters.

Function Code	Name	Default	Minimum Unit	Setting Range
P6-16	Inspection Speed	0	1	0-7

This function code is used to set the preset speed for inspection. See Chapter 7 Inspection Running.

Function Code	Name	Default	Minimum Unit	Setting Range
P6-17	Power Failure Emergency Running	0	1	0-2

0: Disable the power failure emergency running function

1: UPS power supply running

2: 48V battery supply running

For use of the power failure emergency running function, see Chapter 7.

Function Code	Name	Default	Minimum Unit	Setting Range
P6-18	Minimum Input of Analog	0.00V	0.01V	0.00-10.00V
P6-19	Corresponding Setting of Minimum Input of Analog	0.0%	0.1%	0.0-100.0%
P6-20	Maximum Input of Analog	10.00V	0.01V	0.00-10.00V
P6-21	Corresponding Setting of	100.0%	0.1%	0.0-100.0%

A1200 Series

	Maximum Input of Analog			
P6-22	Analog Input Filter Time	0.10s	0.01s	0.00-1.00s

The function code above defines the speed setting of A1200 series inverter under analog control mode and the relationship between analog input voltage and the setting value represented by analog input. The part of analog input voltage exceeding the maximum input or minimum input range will be calculated as the maximum input or minimum input.

If analog input is current input, 1mA current is equivalent to 0.5V voltage.

If AI1 or AI2 is set in P0-02, then percentage parameter of the speed of this speed channel(formed through P6-18 - P6-22) relative to the maximum frequency or rated frequency is the present speed setting.

Function Code	Name	Default	Minimum Unit	Setting Range
P6-23	Inverter Function 1	48	1	0-65535

This parameter is used to select some function settings of the inverter, each having one purpose, as shown below:

P6-23 Inverter Function 1			
Bit	Function Definition	Meaning	Default
Bit0	Function of Stop and Remove Current	0: Disabled 1: Enabled	0
Bit1	Sensorless Compensation Function	0: Disabled during autotuning 1: Enabled during autotuning	0
Bit2	Stop and Waiting Options	0: The inverter stops when external commands are canceled or the waiting time exceeds 5s 1: The inverter stops only when external commands are canceled	0
Bit4	Upper Limit of Maximum Frequency	0: Upper limit of the maximum frequency(P0-05) is 90.00Hz 1: Upper limit of the maximum frequency (P0-05) is the motor rated frequency	1
Bit5	Analog Frequency Setting	0: Calculated according to the maximum frequency 1: Calculated according to the rated frequency	1

Function Code	Name	Default	Minimum Unit	Setting Range
P6-24	Voltage Setting Under Motor Overheating	0.00V	0.01V	0.00-11.00V

This function code generally uses AI2 terminal to judge motor overheating. When P6-24 is not set

as 0:

Motor overheating will not be judged by input terminal function of P4 Group; when the voltage input of AI2 terminal is always greater than the voltage set by P6-24 (filter time 0.5s), the inverter sends the Err39 “motor overheating protection”; if the voltage of AI2 terminal is always lower than P6-24 setting (filter time 2s), motor overheating fault will be reset automatically;

As the resistance of thermometer R2 is 1.33k, it is recommended to set R1 as 2.0k and P6-24 as 3.9V. The wiring mode is as follows:

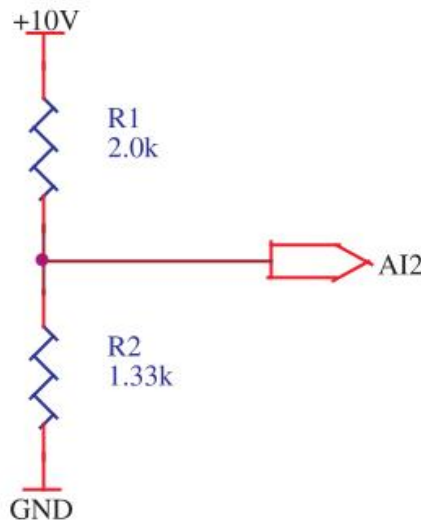

Figure 6-9 Wiring Mode of Thermometer

Wiring mode with the inverter: +10V, GND and AI2 in the figure above are respectively connected to +10V, GND and AI2 terminal on control board of the inverter.

Function Code	Name	Default	Minimum Unit	Setting Range
P6-25	Inverter Function 2	0	1	0-65535

This parameter is used to select some function settings of the inverter, each having one purpose, as shown below:

P6-25 Inverter Function			
Bit	Function Definition	Meaning	Default
Bit0	SPI Communication Fault Detection	0: Enabled 1: Disabled	0
Bit1	PA-03, 05 Property Change	0: Note1 1 of PA-03 and 05 can only be modified under operation panel control mode 1: PA-03 and 05 can be modified under all modes	0
Bit2	Fault Reset	0: Err16, 17 and 33 can not be reset manually 1: Err16, 17 and 33 can be reset manually	0
Bit4	Sensorless Compensation Function	0: Disabled during emergency running 1: Non-disabled during emergency	0

A1200 Series

		running	
Bit5	Conditions of Big Speed Deviation	0: Speed deviation exceeds the setting range of PC-12 and the feedback frequency exceeds 1/4 of the rated frequency; 1: Speed deviation exceeds the setting range of PC-12	0

Function Code	Name	Default	Minimum Unit	Setting Range
P6-27	Zero Speed Signal Output Delay	0ms	1ms	0-9999ms

When the output frequency is changed to zero, the inverter starts counting and will output zero speed signal after the time reaches this parameter value.

Function Code	Name	Default	Minimum Unit	Setting Range
P6-28	Upper Limit of Emergency Running Speed	8.00Hz	0.01Hz	0.0--Maximum Frequency

This function code is used to limit the emergency running speed. When the emergency running speed is detected greater than this value, the inverter will report Err32 fault.

P7 Group: Auxiliary Function Parameter

A1200 elevator inverter offers four groups of acceleration/deceleration time, which correspond to four groups of S curves. Each S curve can be set flexibly according to user's needs.

Function Code	Name	Default	Minimum Unit	Setting Range
P7-00	Acceleration Time 1	4.0s	0.1s	1.0-100.0s
P7-01	Deceleration Time 1	4.0s	0.1s	1.0-100.0s
P7-02	S Curve Start Section Proportion	40.0%	0.1%	10.0-40.0%
P7-03	S Curve End Section Proportion	40.0%	0.1%	10.0-40.0%

Function Code	Name	Default	Minimum Unit	Setting Range
P7-04	Acceleration Time 2	4.0s	0.1s	1.0-100.0s
P7-05	Deceleration Time 2	4.0s	0.1s	1.0-100.0s
P7-06	S Curve 2 Start Section Proportion	40.0%	0.1%	10.0-40.0%
P7-07	S Curve 2 End Section Proportion	40.0%	0.1%	10.0-40.0%

Function Code	Name	Default	Minimum Unit	Setting Range
P7-08	Acceleration Time 3	4.0s	0.1s	1.0-100.0s

P7-09	Acceleration Time 3	20.0s	0.1s	1.0-100.0s
P7-10	S Curve 3 Start Section Proportion	40.0%	0.1%	10.0-50.0%
P7-11	S Curve 3 End Section Proportion	40.0%	0.1%	10.0-50.0%

Function Code	Name	Default	Minimum Unit	Setting Range
P7-12	Acceleration Time 4	1.0s	0.1s	0.5-100.0s
P7-13	Acceleration Time 4	1.0s	0.1s	0.5-100.0s
P7-14	S Curve 4 Start Section Proportion	40.0%	0.1%	10.0-50.0%
P7-15	S Curve 4 End Section Proportion	40.0%	0.1%	10.0-50.0%

These four groups of acceleration/deceleration time are same in meaning. The speed acceleration/deceleration time and characteristics of S curves of each section(preset speeds) through P6-08 --P6-15 when the inverter is running can be selected.

Acceleration time refers to the time t_1 required for the speed accelerated from 0Hz to the maximum output frequency (P0-05)

Deceleration time refers to the time t_2 required for the speed decelerated from the maximum output frequency (P0-05) to 0Hz.

See the figure below:

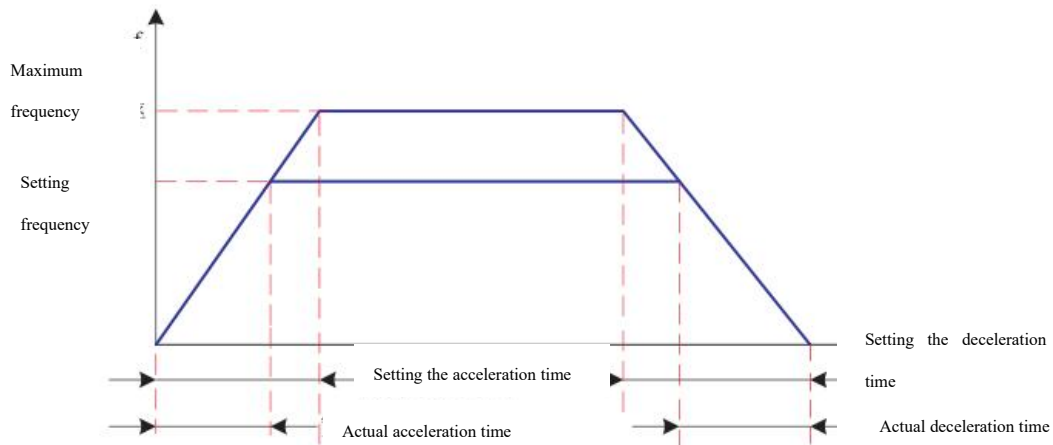

Figure 6-10 Acceleration/Deceleration Time

When the setting frequency is greater than the maximum output frequency, the actual acceleration/deceleration time is the acceleration/deceleration time set.

When the setting frequency is less than the maximum output frequency, the actual acceleration time is equal to the setting value (setting frequency/maximum frequency). A1200 elevator inverter has four groups of different S curves, the acceleration and deceleration combination of each group are symmetrical. By taking the acceleration of S curve 1: T_1 is the parameter defined by P7-02. During this period, the gradient for the output frequency changes (i.e., speed variation rate, same

below) increases gradually. T2 is the time value defined through P7-03. During this time period, gradient for the output frequency changes gradually decreases to zero. During the time period of t1 and t2, the gradient for the output frequency changes is fixed.

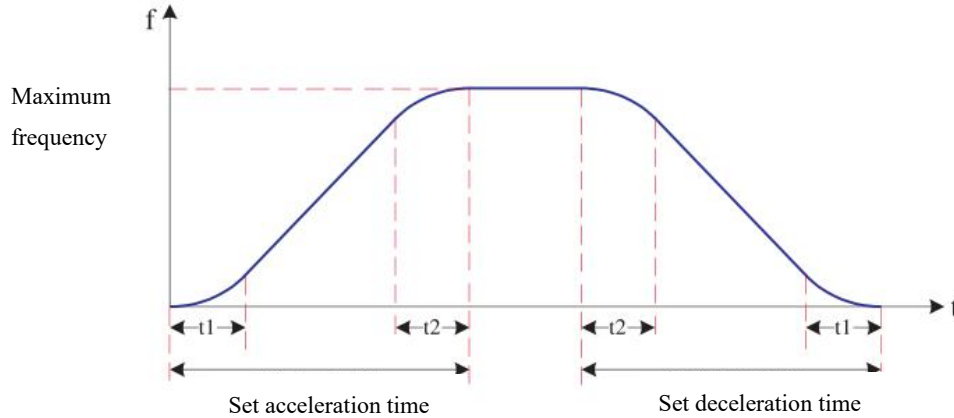

Figure 6-11 S Curve Acceleration/Deceleration

Therefore, under the preset speed control mode, A1200 elevator inverter can offer different S curves for different running periods of the elevator through switching between combinations of preset speeds, which can ensure reasonable speed changes during running and improve users' comfort when they take the elevator.

Function Code	Name	Default	Minimum Unit	Setting Range
P7-16	Slipping Test Acceleration Time	1.0s	0.1s	0.5-10.0s

This function code is used to set the acceleration speed under the slipping test mode. See figure 6-10 for specific use. When conducting slipping test, decrease this parameter appropriately if the slipping effect is not obvious.

Function Code	Name	Default	Minimum Unit	Setting Range
P7-17	Direct Stop Setting Distance	0.0mm	0.1mm	0.0-6553.5mm

This function code is used to set the running distance when the elevator stops directly. Please refer to section 7.7 for detail.

Function Code	Name	Default	Minimum Unit	Setting Range
P7-18	Actual Running Distance of Direct Stop	0.0mm	0.1mm	0.0-6553.5mm

This function code is used to monitor the actual running distance during direct stopping process and assist with debugging. Please see Section 7.7 for detail.

P8 Group: Auxiliary Control Parameter

Function Code	Name	Default	Minimum Unit	Setting Range
P8-00	Status Indicator of Input and Output Terminal	-	-	-

P8-00 indicates the status of input and output terminals. Digital nixie tubes are arranged in the

A1200 Series

sequence from left to right: 5, 4, 3, 2, 1. The definition of each section of digital nixie tube is as below:

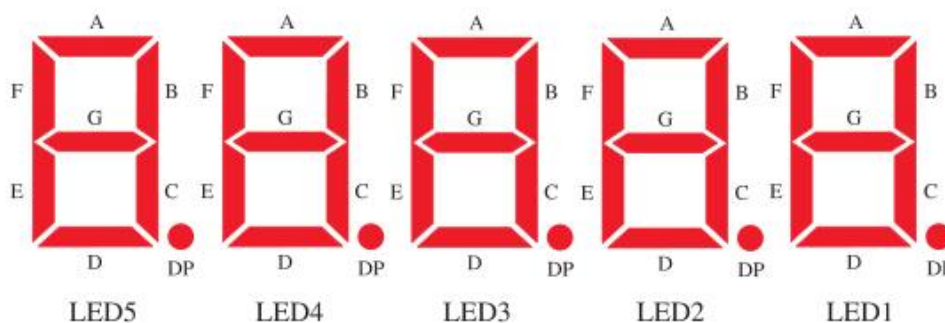

Among them, 3, 4 and 5 represent the status of input terminal and output terminal of the inverter, which are represented by digital sections; 1 and 2 bit are not used.

The definition of each section of digital nixie tubes is as shown below:

Sequence of digital nixie tubes	Sign of digital nixie tubes	Definition of digital nixie tube is on
3	A	DI1 input enabled (the input point is connected to the public terminal)
	B	DI2 input enabled
	C	DI3 input enabled
	D	DI4 input enabled
	E	DI 5 input enabled
	F	DI 6 input enabled
	G	DI 7 input enabled
	DP	DI 8 input enabled
4	A	DI 9 input enabled
	B	DI 10 input enabled
	C-F-DP	Not used
5	A	FM output enabled
	B	DO1 input enabled
	C	DO2 input enabled
	D	Relay 1 output enabled
	E	Relay 2 output enabled
	F-H-DP	Not used

Function Code	Name	Default	Minimum Unit	Setting Range
P8-01	LED Running Display Parameter	32767	1	1-32767

A1200 Series

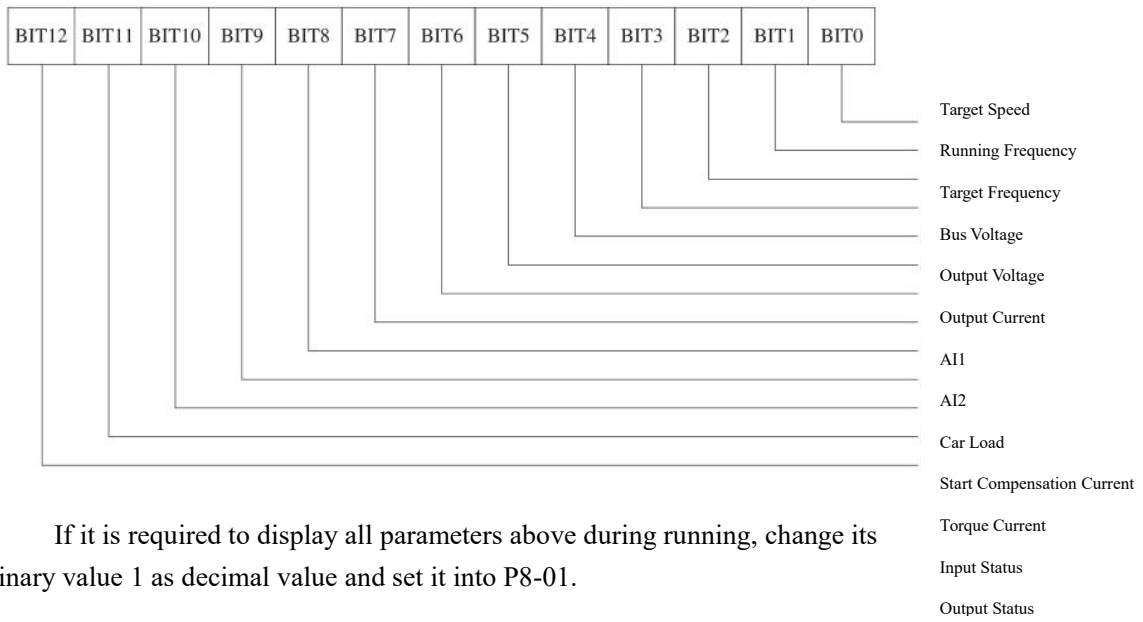

If it is required to display all parameters above during running, change its binary value 1 as decimal value and set it into P8-01.

Function Code	Name	Default	Minimum Unit	Setting Range
P8-02	LED Stop Display Parameter	255	1	1-255

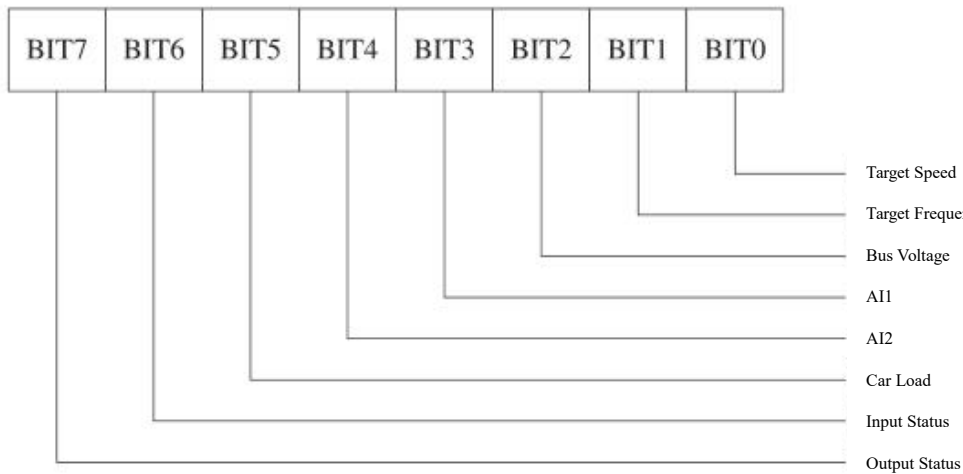

If it is required to display all parameters above during running, change its binary value 1 as decimal value and set it into P8-02.

Function Code	Name	Default	Minimum Unit	Setting Range
P8-03	Elevator Rated Speed	1.600m/s	0.001m/s	0.001-8.000m/s

This parameter is used to set the car speed when the motor runs at rated frequency.

Function Code	Name	Default	Minimum Unit	Setting Range
P8-04	Radiator Temperature	-	1 °C	0-100 °C

This function code displays the radiator temperature in contact with IGBT. The overtemperature protection value of IGBT of different models may be different. A1200 elevator inverter has

automatic processing procedure inside.

Function Code	Name	Default	Minimum Unit	Setting Range
P8-05	Control Board Software Version	-	0.01	0.00-99.99

This function code represents the version no. of the control board software.

Function Code	Name	Default	Minimum Unit	Setting Range
P8-07	Setting Running Time	0h	1h	0-65500h

This function code is used to preset the running time of the inverter.

When the accumulated running time (P8-08) reaches to the running time set, the multi-function digital DO of the inverter outputs the signal of running time reach, and the inverter stops running.

If P8-07 is set as 0, this function is disabled.

Function Code	Name	Default	Minimum Unit	Setting Range
P8-08	Accumulated Working Time	0h	1h	0-65500h
P8-09	Accumulated Seconds	0s	1s	0-3600s

When the inverter is running, P8-09 will be increased once per second and will be reset when it reaches to 3600h. Meanwhile, P8-08 accumulates 1.

Function Code	Name	Default	Minimum Unit	Setting Range
P8-10	High Bit of Running Times	0	1	0-9999
P8-11	Low Bit of Running Times	0	1	0-9999

When the elevator is running, each time the elevator runs, the running times of A1200 elevator inverter will add 1. When the low bit of running times exceeds 9999, the time will be added to the high bit. Therefore, 1 of P8-10 refers to the actual running times 10000.

Function Code	Name	Default	Minimum Unit	Setting Range
P8-12	Short Circuit Protection Detection Between Circuit and Ground	0	1	0, 1

0: Disabled

1: Enabled

This function code is used to determine whether to detect motor short circuit to ground when the inverter is powered on. If this function is enabled, the inverter has short period of output when the inverter is powered on.

Function Code	Name	Default	Minimum Unit	Setting Range
P8-17	Year	2014	1	2000-2100
P8-18	Month and Day	2014	0101	0101-1231
P8-19	Hour and Minute	00.00	00.01	00.00-23.59

This function code is used to set the inverter time.

P9 Group: Protection Function Parameter

Function Code	Name	default	Minimum Unit	Setting Range
P9-09	Fault Automatic Reset Times	0	1	0-3

When the inverter adopts fault automatic reset function, this function code is used to set the automatic reset times within 1h after occurrence of fault. When the times exceed this value, the inverter will be in standby mode, waiting for inspection.

Function Code	Name	Default	Minimum Unit	Setting Range
P9-11	Fault Automatic Reset Interval	1.0s	0.1s	0.1-100.0s

This function code refers to the waiting time from fault alarm to automatic reset.

Function Code	Name	default	Minimum Unit	Setting Range
P9-12	Input Phase Loss Protection	1	1	0, 1

0: Disabled

1: Enabled

This function code is used to determine whether to conduct input phase loss protection.

Function Code	Name	Default	Minimum Unit	Setting Range
P9-13	Output Phase Loss Protection	1	1	0-3

This function code is used to determine whether to conduct output phase loss protection.

P9-13 Output Phase Loss Protection				
Bit	Function Definition	Meaning	Default	
Bit0	Output Phase Loss Detection During Running	0: Disabled; 1: Enabled	1	
Bit1	Output Phase Loss Detection At Start	0: Disabled; 1: Enabled	1	

Function Code	Name	Default	Minimum Unit	Setting Range
P9-14	First Fault Type	0	1	0-60
P9-15	First Fault Subcode	0	1	0-999
P9-16	First Fault Month/Day	0	1	0-1231
P9-17	First Fault Time	0	0.01	00.00-23.59
P9-18	Second Fault Type	0	1	0-60
P9-19	Second Fault Subcode	0	1	0-999
P9-20	Second Fault Month/Day	0	1	0-1231
P9-21	Second Fault Time	0	0.01	00.00-23.59
...
P9-50	Tenth Fault Type	0	1	0-60
P9-51	Tenth Fault Subcode	0	1	0-999
P9-52	Tenth Fault Month/Day	0	1	0-1231
P9-53	Tenth Fault Time	0	0.01	00.00-23.59

A1200 Series

P9-54	Latest Fault Type	0	1	0-60
P9-55	Latest Fault Subcode	0	1	0-999
P9-56	Latest Fault Month/Day	0	1	0-1231
P9-57	Latest Fault Time	0	0.01	00.00-23.59
P9-58	Latest Logic Information	0	1	0-65535
P9-59	Latest Setting Frequency	0.00Hz	0.01Hz	0.00-99.00Hz
P9-60	Latest Feedback Frequency	0.00Hz	0.01Hz	0.00-99.00Hz
P9-61	Latest Bus Voltage	0.0V	0.1V	0.0-6500.0V
P9-62	Latest Output Voltage	0V	1V	0-65000V
P9-63	Latest Output Current	0.00A	0.01V	0.00-650.00A
P9-64	Latest Torque Current	0.00A	0.01A	0.00-650.00A
P9-65	Latest Output Power	0.00KW	0.01KW	0.00-99.99KW
P9-66	Latest Input Function Status 1	0	1	0-65535
P9-67	Latest Input Function Status 2	0	1	0-65535
P9-68	Latest Output Function Status 1	0	1	0-65535
P9-69	Latest Output Function Status 2	0	1	0-65535

This function parameter group records the type, subcode and date & time of occurrence of the latest 11 faults; and the logic status, output frequency, output current, bus voltage, input and output status and other information upon occurrence of the last fault.

Please see Chapter 8 for detailed definition of fault type.

PA Group: PG Parameter

A1200 elevator inverter offers induction motor vector control and permanent magnet synchronous motor vector control. Configure different rotary encoder interface cards(PG card) according to the encoder selected and set following parameters correctly according to specific model of encoder and PG card.

Function Code	Name	Default	Minimum Unit	Setting Range
PA-00	Encoder Pulse Count	1024	1	100-9999

Rotary encoder of motor is essential for general elevator application. PA-00 refers to the pulse count of rotary encoder per rotation. During use, users must set this parameter properly, otherwise it may result in overcurrent and other abnormalities during running.

Function Code	Name	Default	Minimum Unit	Setting Range
PA-01	Encoder Disconnection Detection Time	1.0s	0.1s	0.0-10.0s

If the pulse signal of encoder is lost when the elevator is running, it is impossible to control motor properly. A1200 elevator inverter will detect the pulse signal of rotary encoder all the time. When it detects that the pulse signal abnormality lasts longer than the time set by PA-01, A1200 elevator

A1200 Series

inverter will send alarm (encoder fault) and stop running. When PA-01 is set as 0, alarm function is canceled.

Function Code	Name	Default	Minimum Unit	Setting Range
PA-03	Magnetic Pole Angle of Encoder	0.0	0.1	0.0-359.9

When A1200 elevator inverter conducts control on permanent magnet synchronous motor, it requires the initial angle of encoder to judge the rotor position of motor. In order to ensure high accuracy control in different directions, A1200 records the initial angle of encoder through PA-03. This function code is acquired by autotuning the encoder angle during motor autotuning, and can be set by users themselves if they have understood the system conditions.

Only when this parameter is set properly, A1200 elevator inverter can control the synchronous motor; but this parameter is not required for induction motor control.

By default, PA-03 and 05 (magnetic pole angle and wiring mode) can only be modified when P0-01=1; after changes, P0-01 can be changed as 1 after the inverter is powered on again.

Function Code	Name	default	Minimum Unit	Setting Range
PA-04	Present Angle of Encoder	0.0	0.1	0.0-359.9

During control on permanent magnet synchronous motor, encoder will feedback the position of motor rotor to PA-04 of the inverter timely. This parameter is the key for high accuracy control of permanent magnet synchronous motor.

PA-04 has power failure memory function and is only relative to synchronous motor control and has no relation with induction motor control.

Function Code	Name	Default	Minimum Unit	Setting Range
PA-05	Wiring Mode	0	1	0-15

PA-05 is enabled only for synchronous motor application, and represents the wiring combination mode of the motor.

Function Code	Name	Default	Minimum Unit	Setting Range
PA-06	PG Card Frequency Division Ratio	1	1	1-256

When the direct stop function is enabled, the inverter mainboard requires to acquire the pulse signal of encoder through the frequency division output terminal of PG card. So it is required to set this parameter as the frequency division factor of PG card.

With regards to the frequency division coefficient ration of PG card, please refer to the 3.2.3.4 Wiring & Description of PG Card of Special Rotary Encoder Interface Board of the Elevator.

PB Group: Communication Parameter (Not Used)

PC Group: Special Enhancement Function Parameter

Function Code	Name	default	Minimum Unit	Setting Range
PC-00	Command Abnormality Action	1	1	0, 1

0: Ramp-to stop normally

1: Lock output immediately

A1200 Series

Command abnormality refers to that running commands of A1200 are disabled suddenly when the elevator is running (see the figure below). At this time, A1200 will process the abnormality according to PC-00. Ramp-to-stop refers to that the inverter will slow down steadily and stop according to normal control logic to avoid sudden elevator speed variation; locking output immediately is to turn off the brake immediately to cut off running contactor output.

FWD	REV	Meaning of Commands
OFF	OFF	Disabled
ON	OFF	Forward
OFF	ON	Reverse
ON	ON	Disabled

Function Code	Name	Default	Minimum Unit	Setting Range
PC-01	Abnormality Deceleration Time	3.0s	0.1s	0.0-300.0s

This function code refers to the time required for the inverter speed decelerated from the maximum frequency to 0Hz in case of inverter fault.

Function Code	Name	Default	Minimum Unit	Setting Range
PC-02	Up Speed Detection Level	45.00Hz	0.01Hz	0.00Hz--Maximum frequency
	Down Speed Detection Level	45.00Hz	0.01Hz	0.00Hz--Maximum frequency

PC-02 and PC-03 are the method adopted by A1200 elevator inverter to forced the elevator to slow down. These two function codes represent different judgment level when the elevator goes up and down (Note: the forward command received by the inverter, the elevator goes up; upon receiving the reverse command, the elevator will goes down correspondingly). The inverter will check if the present running frequency exceeds the detection level set by PC-02 and PC-03 immediately upon input of up(down) speed judgment signal (forced deceleration switch signal); if the present running frequency exceeds the detection level, the inverter will ramp to stop according to the deceleration time set by PC-01. Besides, when the elevator goes up, the down frequency judgment signal is disabled and vice verse.

Therefore, the forced deceleration running principle of A1200 elevator inverter is as follows:

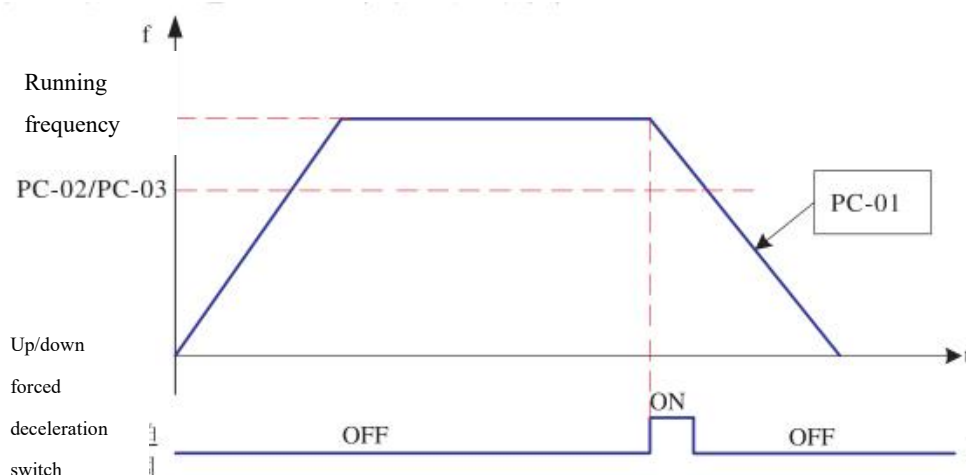

Figure 6-12 Forced Deceleration Running Principle

Function Code	Name	Default	Minimum Unit	Setting Range
PC-04	Advance Door Opening Level	5.00Hz	0.01Hz	0.00Hz--Maximum frequency

With A1200 elevator inverter, it will be very convenient to complete the advance door opening function: When the elevator runs slowly and if the output frequency is lower than the parameter set by PC-04, A1200 elevator inverter will output the advance door opening signal through the output terminal until the elevator stops.

Function Code	Name	Default	Minimum Unit	Setting Range
PC-05	Frequency Detection Level 1(FDT Frequency 1)	50.00Hz	0.01Hz	0.00Hz--Maximum frequency
PC-06	Frequency Detection Level 2(FDT Frequency 2)	50.00Hz	0.01Hz	0.00Hz--Maximum frequency
PC-07	Frequency Detection Lag (FDT Lag)	5.0%	0.1%	0.0-100.0%

As shown in the figure below, PC-05 -PC-07 are parameters relative to FDT output signals. FDT1 and FDT 2 may be different. FDT lag: FDT Frequency * PC-07.

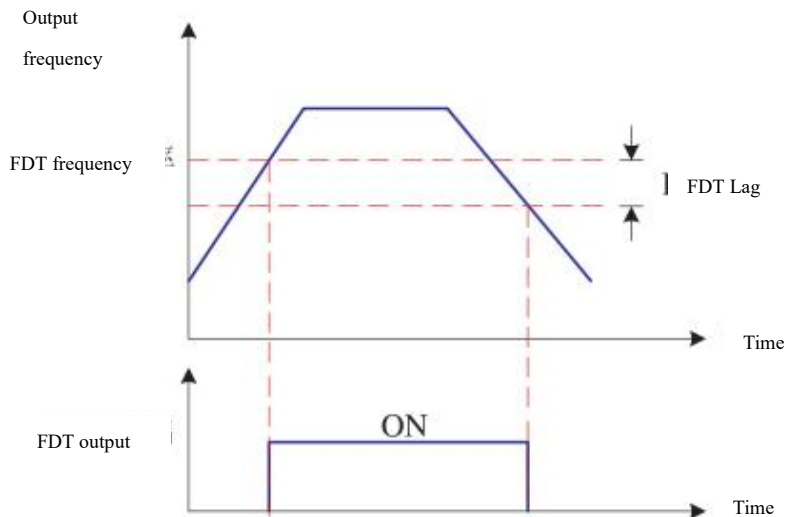

Figure 6-13 FDT Signal Output Principle

Function Code	Name	Default	Minimum Unit	Setting Range
PC-08	Frequency Reach Detection Width	0.0%	0.1%	0.0-100.0%

When the output frequency of the inverter reaches to the setting frequency, this parameter can adjust its detection width. As shown below:

Detection width value: Maximum frequency × PC-08

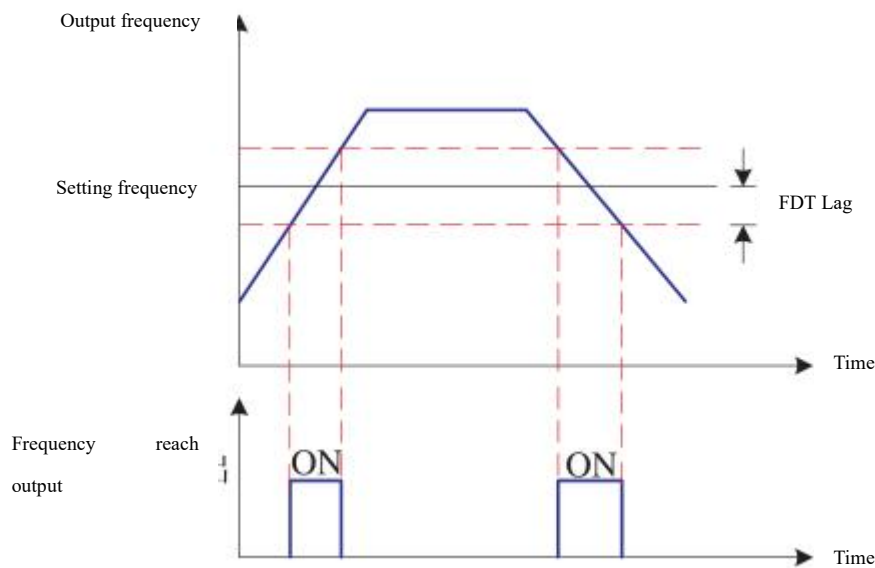

Figure 6-14 Frequency Reach Signal Output Principle

Function Code	Name	Default	Minimum Unit	Setting Range
PC-09	Overspeed Judgment Level	115%	1%	80-120%
PC-10	Overspeed Detection Delay	1.0s	0.1s	0.0-5.0s

A1200 elevator inverter has overspeed detection function and it can judge if the present running frequency is excessive based on the function parameter setting of PC-09. If the accumulated overspeed time is greater than PC-10, the inverter is judged in overspeed status.

Among these two function codes, overspeed judgment level is the percentage of maximum frequency, i.e., 100% corresponds to the maximum frequency.

When the inverter is in overpseed status, it will take corresponding measures according to PC-11 function setting. Ramp to stop under abnormality is that the inverter will ramp to stop according to the deceleration time set by FC-01.

Function Code	Name	Default	Minimum Unit	Setting Range
PC-11	Overspeed Action	1	1	0-2

- 0: Ramp to stop under abnormality
- 1: Send alarm immediately and lock output
- 2: Continue to run

Ramp to stop under abnormality is to ramp to stop according to the deceleration time set by PC-01.

Function Code	Name	default	Minimum Unit	Setting Range
PC-12	Speed Deviation Judgment Level	30%	1%	0-50%
PC-13	Speed Deviation Detection Delay	1.0s	0.1s	0.0-5.0s

A1200 elevator inverter has speed deviation detection function and can judge if the deviation between the present running frequency and the setting frequency is too large. If the accumulated

time of large deviation is greater than PC-13, it will be considered that the present speed deviation is too large.

Of these two function codes, speed deviation judgment level is the percentage of maximum frequency.

If the speed deviation is too large, A1200 will take corresponding measures according to function setting of PC-14.

Function Code	Name	Default	Minimum Unit	Setting Range
PC-14	Action Upon Excessive Speed Deviation	2	1	0-2

0: Ramp to stop under abnormality

1: Send alarm and lock output immediately

2: Continue to run

Ramp to stop under abnormality is to ramp to stop according to the deceleration time set by PC-01

PD Group: Special Function Parameter

Function Code	Name	Default	Minimum Unit	Setting Range
PD-00	Torque Boost	1.0%	0.1%	0.1-30.0%
PD-01	Torque Boost Frequency	50.00Hz	0.01Hz	0.00-Maximum Frequency

Under V/F control mode, in order to compensate low-frequency torque characteristics, conduct boost compensation for the inverter output frequency under low frequency.

Excessive torque boost may result in motor overheating and overcurrent of inverter. Generally, torque boost shall not exceed 10%.

Effective adjustment of this parameter can avoid overcurrent upon start; for overload, it is recommended to increase this parameter. When the load is light, decrease this parameter value.

If the torque boost is set as 0, the inverter adopts automatic torque boost.

Under the torque boost frequency set by PD-01, torque boost is enabled. if the boost frequency exceeds this setting frequency, the torque boost is invalid.

Output voltage

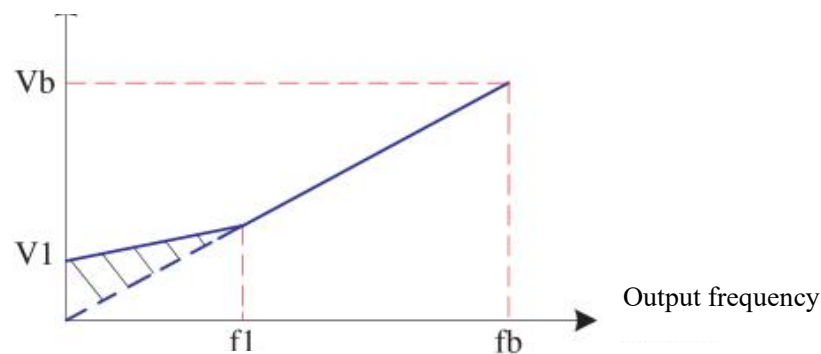

V1: Manual torque boost voltage

Vb: Maximum output voltage

f1: Torque Boost End Frequency

fb: Basic running frequency

Figure 6-15 Manual Torque Boost

Function Code	Name	default	Minimum Unit	Setting Range
PD-02	Slip Compensation	100.0%	0.1%	0.2-200.0%
PD-03	Oscillation Suppression Gain	20	1	0-100

PD-02 slip compensation is enabled under V/F control mode. Setting this parameter can compensate slip caused by loads under V/F control mode to make the variation of motor rotation speed along with load changes smaller. Generally 100% corresponds to the rated slip of motor with rated load. Adjust the slip factor according to following principles: Under rated load, if the slip compensation factor is set as 100%, the rotation speed of inverter motor is basically close to the setting speed. If the load is lighter than rated load, this factor may be less than 100%, otherwise this factor may be slightly greater than 100%.

PD-03 Oscillation Suppression Gain shall be set as 0 if there is no motor oscillation. Only when there exists obvious motor oscillation, which results in the motor runs abnormally, increase this gain. The higher the gain is, the better the oscillation suppression effect will be. Setting mode of this parameter: This gain shall be set lower as much as possible on the condition of ensuring effective motor oscillation suppression effect.

Function Code	Name	Default	Minimum Unit	Setting Range
PD-04	Inverter Function 3	0	1	0-65535

This parameter is used to set some functions of the inverter, each bit having a purpose, as shown below:

PD-04 Inverter Function 3			
Bit	Function Definition	Meaning	Default
Bit0	Induction Motor Current Loop Parameter	0: Fixed value 1: Set by P2-06 and P2-07	0

Function Code	Name	Default	Minimum Unit	Setting Range
PD-05	Zero Servo Current Factor	15.0%	0.1%	1.0-50.0%
PD-06	Zero Servo Speed Loop KP	0.50	0.01	0.05-1.00
PD-07	Zero Servo Speed Loop K1	0.60	0.01	0.05-2.00

This parameter group is used to regulate elevator start when there is no weighing sensor. Please see Section 7.6 for specific description.

PU Group: Monitoring Parameter

Function Code	Name	Default	Minimum Unit	Setting Range
PU-00	Pre-torque Current	0.0%	0.1%	-200.0-200.0%

This function code is used to display the percentage of pre-torque current in the rated current (display with “+” and “-”, power-driven or generating state).

Function Code	Name	Default	Minimum Unit	Setting Range
PU-01	Logic Information	0	1	0-65535

Display the elevator status parameter.

As shown below, five digital nixie tubes are represented by 1, 2, 3, 4 and 5 respectively from right to left. Combination of 1 and 2 indicates the running status of inverter; 3 refers to the present preset speed; 4 represents direction commands; 5 indicates if running is permitted at present. Specific contents are as follows:

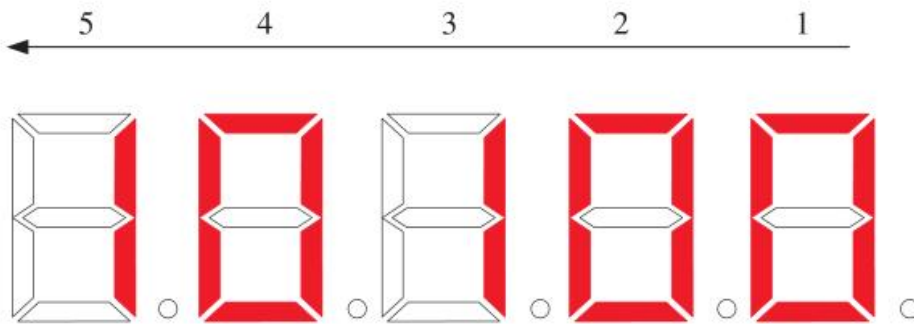

Figure 6-16 Example of Logic Information

5		4		3		2		1
Terminal Running Permission		Direction Command		Preset Setting	Speed	Running status		
0	Running disabled	0	No command	0	Preset speed 0	00		Standby status
1	Running enabled	1	Up command	1	Preset speed 1	01	Running contactor control	
		2	Down command	2	Preset speed 2	02	Brake opening control	
				3	Preset speed 3	03	Start zero speed running	
				4	Preset speed 4	04	Normal curve running	
				5	Preset speed 5	05	Emergency running	
				6	Preset speed 6	06	Start frequency	
				7	Preset speed 7	07	Running contactor release	
						08	Direct stop control	
						09	Ramp to stop	
						10	Stop zero speed holding	
						11	Brake release control	
						12	Stop status	
						13	Slip test running	

A1200 Series

				14	Abnormal ramp to stop
--	--	--	--	----	-----------------------

Function Code	Name	default	Minimum Unit	Setting Range
PU-02	Setting Frequency	0.00Hz	0.01Hz	0.00-99.00Hz
PU-03	Feedback Frequency	0.00Hz	0.01Hz	0.00-99.00Hz
PU-04	Bus Voltage	0.0V	0.1V	0.0-65000V
PU-05	Output Voltage	0V	1V	0-65000V
PU-06	Output Current	0.00A	0.01A	0.00-650.00A
PU-07	Output Torque	0.0%	0.1%	0.0-200.0%
PU-08	Torque Current	0.00A	0.01A	0.00-650.00A
PU-09	Output Power	0.00kW	0.01kW	-99.99-99.99kW

These function codes respectively display present performance status(output power is displayed with “+” and “-”).

Function Code	Name	Default	Minimum Unit	Setting Range
PU-10	Car Load	0.0%	0.1%	0.0-100.0%

When the weighing pre-torque function is enabled, this function code displays the car load acquired by weighing.

Function Code	Name	Default	Minimum Unit	Setting Range
PU-11	Car Speed	0.000m/s	0.001m/s	0.000-65.000m/s

Display the car running speed. In order to ensure correct display of this parameter, it is required to set P8-03 properly.

Function Code	Name	Default	Minimum Unit	Setting Range
PU-12	Communication Interference	0	1	0-65535

Respectively display the communication quality between the control board and the driver board. 0-9 represents the communication level. The larger the value is, the communication interference is larger and the communication quality will be poor.

Function Code	Name	Default	Minimum Unit	Setting Range
PU-13	Input Function Status 1	0	1	0-65535
PU-14	Input Function Status 2	0	1	0-65535
PU-15	Output Function Status 1	0	1	0-65535
PU-16	Output Function Status 2	0	1	0-65535

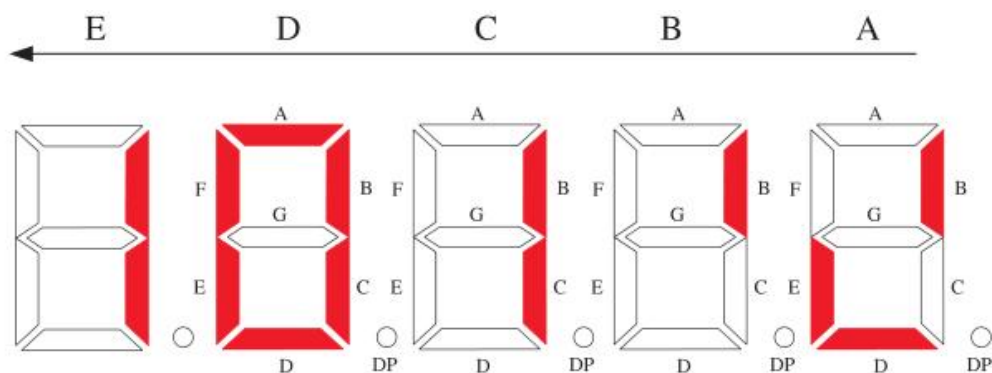

Figure 6-17 Example of Input Status

As shown in figure 6-17, the five digital nixie tubes from right to left are respectively numbered as ABCED; for PU-13 and PU-14 input and output status, values displayed by ED represent the function codes of input and output terminal (for example, 10 represents running contactor feedback); if C is 1, this signal is enabled; if C is 0, this signal is disabled; each section of AB represents one function status. There are 16 sections of digital nixie tubes in total, representing 16 function status. As shown above, CDE indicate the running contactor feedback signal is enabled. Meanwhile, through AB, it can be seen that function code is enabled when it is 10, 2, 4 and 5.

PU-13 Input Function Status 1

Function Code	Function Definition	Function Code	Function Definition
0	Not used	8	Inspection signal
1	Forward command	9	Emergency input
2	Reverse command	10	Running contactor feedback
3	Preset speed terminal 1	11	Brake feedback
4	Preset speed terminal 2	12	Weighing terminal 1
5	Preset speed terminal 3	13	Weighing terminal 3
6	Fault reset command	14	Weighing terminal 3
7	Enable control signal	15	Weighing terminal 4

PU-14 Input Function Status 2

Function Code	Function Definition	Function Code	Function Definition
16	External fault signal	24	Not used
17	Motor overheating signal	25	Not used
18	Up speed judgment	26	Not used
19	Down speed judgment	27	Not used
20	Preset speed logic 1	28	Not used
21	Preset speed logic 2	29	Not used
22	Direct stop command	30	Not used
23	Not used	31	Not used

PU-15 Output Function Status 1

Function Code	Function Definition	Function Code	Function Definition
0	Not used	8	Bus undervoltage

A1200 Series

1	Running	9	FDT1 output
2	Zero speed running	10	FDT2 output
3	Zero speed signal	11	Frequency reach
4	Fault signal	12	Overspeed output
5	Running contactor output control	13	Overload pre-alarm
6	Brake output control	14	Running time reach
7	Advance door opening signal	15	Running ready

PU-16 Output Function Status 2

Function Code	Function Definition	Function Code	Function Definition
16	Contact adhesion output	24	Not used
17	Releveling output	25	Not used
18	Light load running output	26	Not used
19	Not used	27	Not used
20	Not used	28	Not used
21	Not used	29	Not used
22	Not used	30	Not used
23	Not used	31	Not used

Function Code	Name	Default	Minimum Unit	Setting Range
PU-17	AI1 Voltage	0.00V	0.01V	0.00-20.00V

This function code displays the voltage of analog input terminal AI1.

Function Code	Name	default	Minimum Unit	Setting Range
PU-18	AI2 Voltage	0.00V	0.01V	0.00-20.00V

This function code displays the voltage of analog input terminal AI2.

Function Code	Name	default	Minimum Unit	Setting Range
PU-19	AO1 Voltage	0.00V	0.01V	0.00-20.00V

This function code displays the voltage of analog input terminal AO1.

Function Code	Name	default	Minimum Unit	Setting Range
PU-20	Start Slip Pulse Count	0	1	0-65535

When the no-weighing restart function is enabled (F3-09=5), this parameter is used to observe the slip condition upon start. With regards to debugging upon no-weighing restart, please refer to section 7.6.

Function Code	Name	default	Minimum Unit	Setting Range
PU-21	Pulse Count Output of PG Card Per Second	0	1	0-65535

When the direct stop function is enabled, it is required to connect the frequency division signal of PG card to the corresponding terminals of IO expansion board and then transmit the signal to the master control panel of the inverter. During running, user can check if the pulse signal of PG card is normal through this parameter.

PF Group: Manufacturer Parameter (Not Used)

PP Group: User Parameter

Function Code	Name	Default	Minimum Unit	Setting Range
PP-00	User Password	0	1	0-65535

The password protection function is enabled as long as this function code is set as any non-zero digital.

00000: Clear the password set by former users and disable the password protection function.

After user passwords are set and come into effect, A1200 prohibits users to view parameters.

Please keep your password in mind. In case the password is set incorrectly or has been forgotten, please contact the manufacturer.

Function Code	Name	Default	Minimum Unit	Setting Range
PP-01	Parameter Update	0	1	0, 1, 2

0: No operation

1: The inverter resets the parameter to the default.

2: The inverter clears recent fault records.

Function Code	Name	Default	Minimum Unit	Setting Range
PP-02	User Setting Examination	0	1	0, 1

When PP-02 is set as 1, the LED operation panel only displays parameters different from the default, convenient for users to check setting value and troubleshoot problems. If this function code is set as 0, the LED operation panel will display all parameters.

Chapter 7 Application & Debugging

This chapter mainly introduces several application modes of A1200 elevator inverter and its typical working conditions, such as power failure emergency running and inspection running.

7.1 Preset Speed Control Mode

Preset speed control mode is a common elevator control and application mode, which is characterized by strong anti-interference ability, better adaptability and simple to realize. However, under traditional preset speed control mode, acceleration/deceleration curves of different preset speeds are same and influence one another, thus causing user can not take care of all aspects. A1200 elevator inverter is specially designed against characteristics of preset speed control mode: Each preset speed can flexibly correspond to different acceleration/deceleration curve, facilitating users' debugging in actual application.

7.1.1 Wiring diagram of preset speed control system

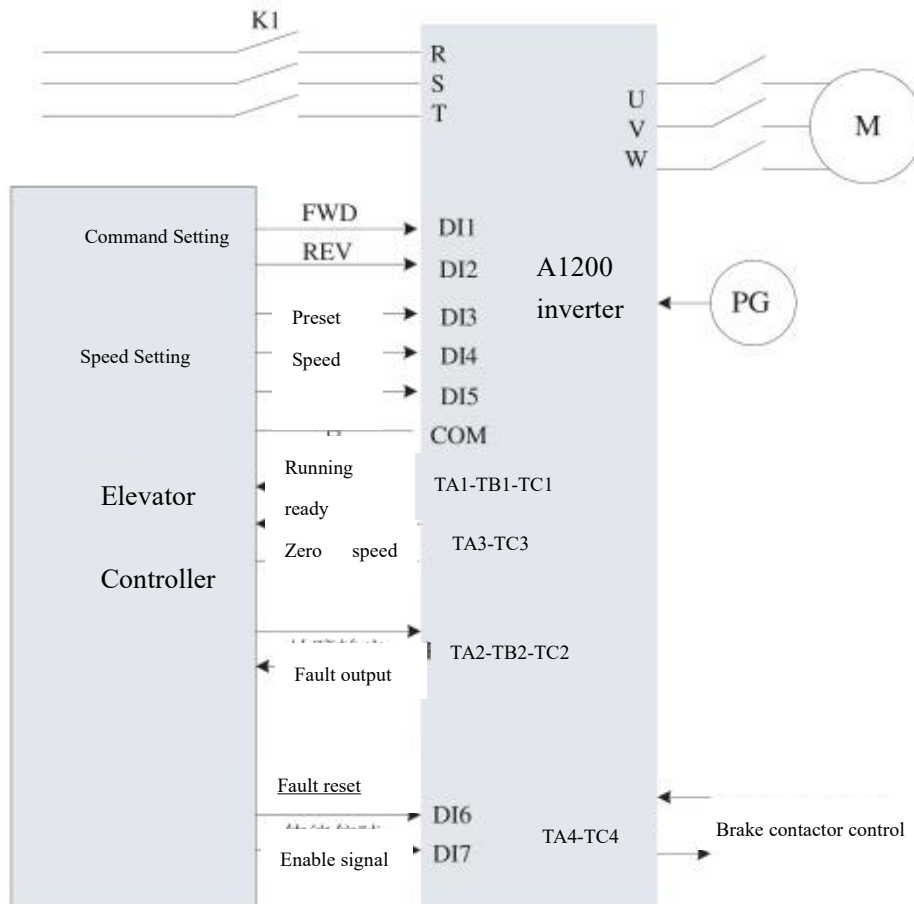

Figure 7-1 Wiring Diagram of Preset Speed Control

Note:

- ◆ 1) In figure 7-1, except TA2-TB2-TC2, function parameters of other input and output points have been configured at the factory and can only be changed when necessary;
- ◆ 2) It is recommended to use RELAY2 of the inverter as the brake control input point and connect it to the brake control circuit of the system.

7.1.2 Parameter setting

This part adjust parameters by three steps against the most typical application mode according to the debugging sequence of the elevator: Motor autotuning, inspection running and normal running.

1. Motor autotuning

- 1) Induction motor autotuning (stationary, dynamic)

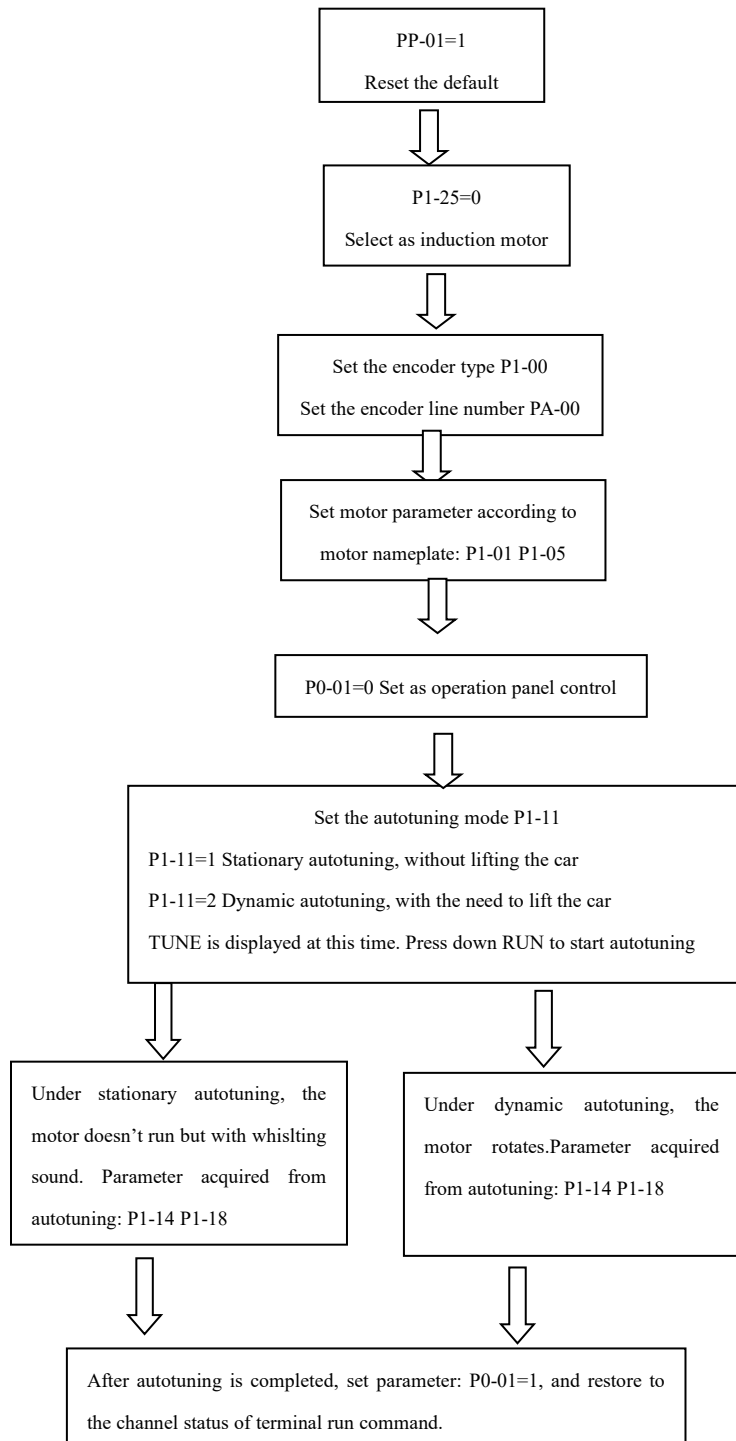

Figure 7-2 autotuning Procedure of Induction Motor

Description: If open-loop vector control or V/F control mode is selected, users do not need to set the encoder type and encoder line number. For elevator running control, closed-loop vector control mode is recommended.

2) Idling autotuning of synchronous motor

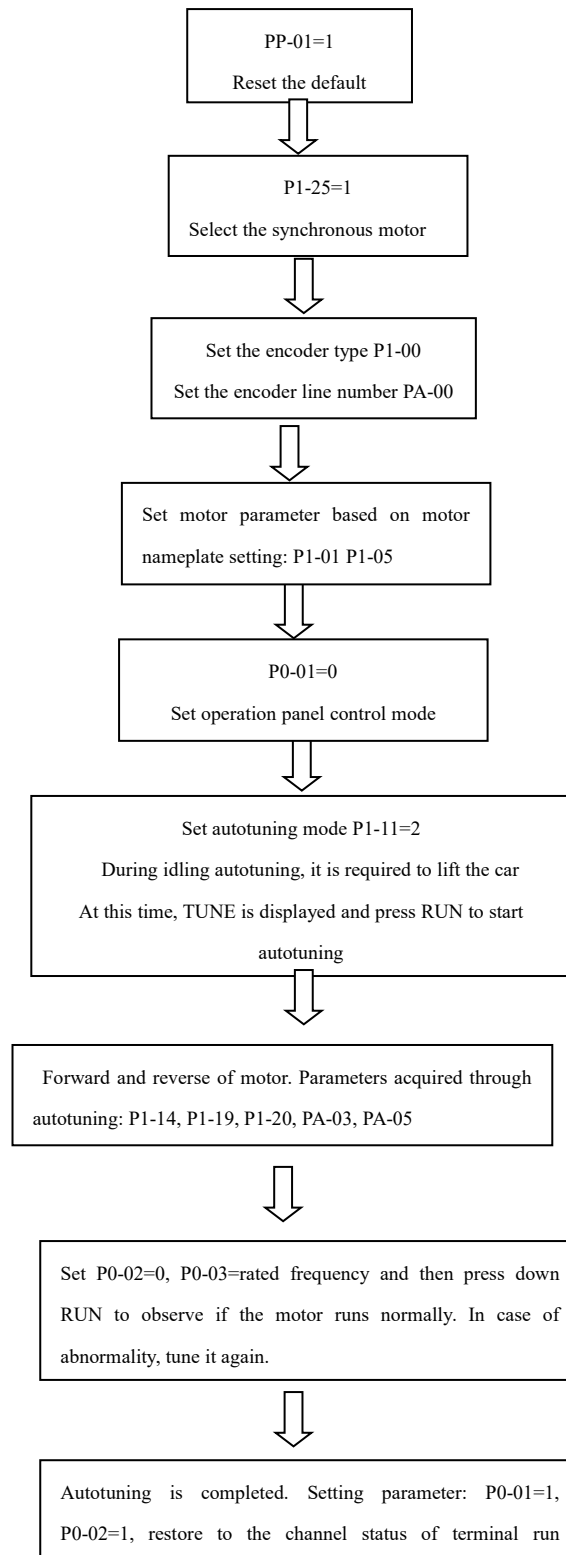

Figure 7-3 Idling Autotuning Procedure of Synchronous Motor

Description: It is recommended to conduct autotuning for several times. Moreover, if the PA-03 error is within 5° , PA-05 remains unchanged and then conduct commissioning.

3) Autotuning for synchronous motor with load

a) Method of application

For convenience of use of synchronous motor in the field, A1200 elevator inverter designs one

kind of encoder angle autotuning mode for synchronous motor with a load. With this method, user can complete encoder angle autotuning without the need to take off the steel rope of elevators. Operation procedures are as follows:

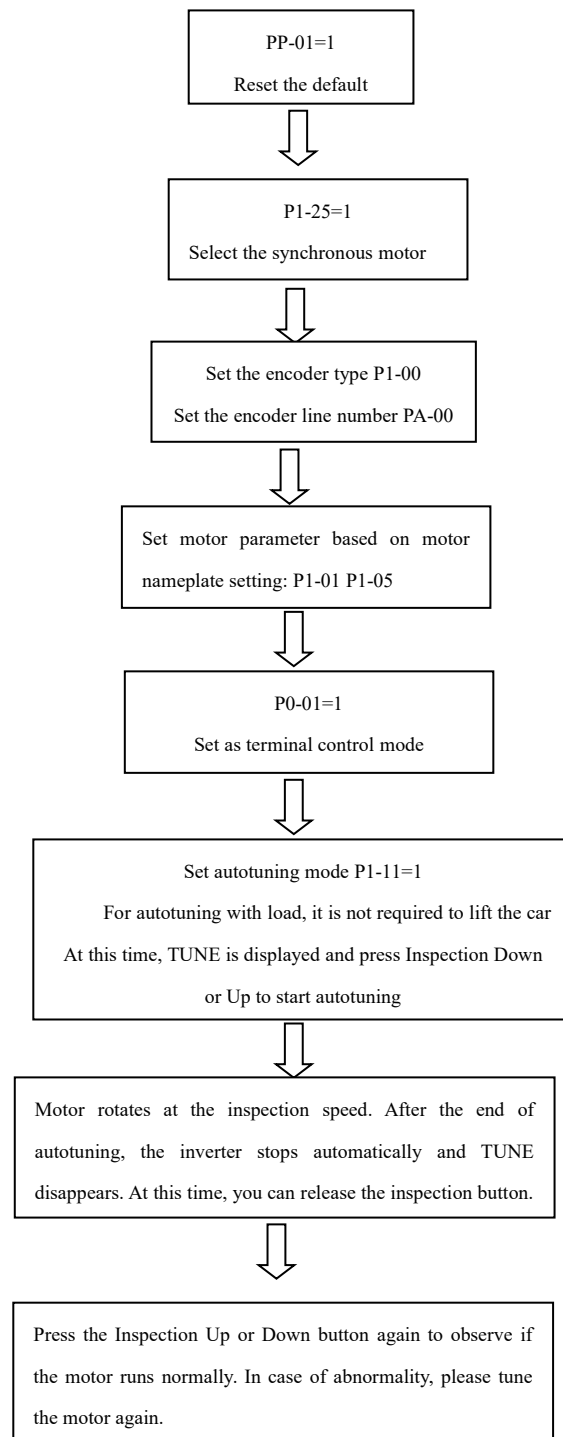

Figure 7-4 Autotuning Procedure for Synchronous Motor with Load

b) Notes

① After autotuning, there will be 2s for the inverter to save parameters. During this period, the inverter will not respond to any input commands.

② Important: Angle autotuning for motor with load must be performed by professional personnel.

Moreover, it is required to ensure there is no person in the hoistway to avoid danger.

③ At the beginning of the autotuning, disable function software that uses sensorless pre-torque compensation(P6-23BIT1=0) to avoid abnormality;

④ If autotuning can not be completed normally, exchange any two output power wires UVW of the inverter and then conduct autotuning again;

2. Inspection running

After autotuning is completed successfully, the inverter will enter the inspection running phase.

Before the inverter enter the inspection running, following parameters shall be set:

- a) Inspection speed (P6-16)
- b) Inspection preset speed frequency (P6-00 -P6-07);
- c) Preset speed acceleration/deceleration curve for inspection running (P6-08 - P6-15);
- d) Specific acceleration/deceleration time of preset speeds for inspection running (P7-00 - P7-15).

Supplementary instruction:

a) P6-16 is used to set the preset speeds for inspection running. If preset speed 2 is adopted, P6-16 shall be set as 2;

b) Then set the running frequency of inspection speed (preset speed 2, P6-02). The inverter output frequency during inspection running is equal to the setting frequency;

c) After the running frequency of inspection speed is set, it is required to select the acceleration/deceleration curve P6-10(default curve: S curve 1) for inspection speed (preset speed 2);

d) If it is required to modify the acceleration/deceleration time of the acceleration/deceleration curves (default curve: S curve 1), P7-00 -P7-03 must be reset.

Description: If the terminal function adopted by the inverter system is not identical to the default function, please check and set corresponding parameters of P4 and P5 groups correctly before inspection running.

3. Normal running

When the elevator enters into the normal debugging phase, it is required to debug the inverter for comfort of elevator. Specific parameters are as follows:

a) Before the elevator runs, please confirm the sequence of encoder wiring and inverter output to phase U, V and W of motor side haven't been exchanged after motor autotuning.

b) Set the target running frequency of each preset speed of speeds.

c) Set corresponding acceleration/deceleration curves for each preset speed.

d) Set the acceleration/deceleration time of each curve and the start and end section of each curve according to comfort.

e) Adjust parameters of P2 group and P3 group based on the comfort during running and at start and stop.

4. Application example

Let us suppose the preset speeds of the inverter are as follows:

Preset speed 2 is adopted for inspection, the target running frequency is 10Hz and the acceleration/deceleration curve is S curve 4;

Preset speed 3 is adopted for crawling, the target running frequency is 3Hz and the acceleration/deceleration curve is S curve 3;

Preset speed 7 is adopted for high speed, the target running frequency is 48Hz and the

acceleration/deceleration curve is S curve 1;

Then parameters of corresponding preset speed are set as below:

Presets Speed	Function Code	Name	Setting value	Remarks
Inspection	P6-16	Inspection Speed	2	
	P6-02	Preset Speed 2	10	
	P6-10	Preset Speed 2 S Curve	4	If it is required to modify S curve 4, please set P7-12 - P7-15 as required
Crawl	P6-03	Preset speed 3	3	
	P6-11	Preset speed 3 S curve	3	If it is required to modify S curve 3, please set P7-08 - P7-11 as required
High speed	P6-07	Preset speed 7	48	
	P6-15	Preset speed 7 S curve	1	If it is required to modify S curve 1, please set P7-00 - P7-03 as required

Note:

- ◆ The example above only involves setting of parameters related to speed sections and other parameters required to be modified for preset speed debugging application are exclusive.

7.2 Analog Control Mode

Another common control mode adopted by A1200 series inverter in elevator application: Analog speed setting mode. Under this control mode, the inverter adopts analog input method for speed setting and terminal input for running command. Control and use of the inverter are described below.

7.2.1 Analog control system wiring diagram

System wiring diagram is as follows:

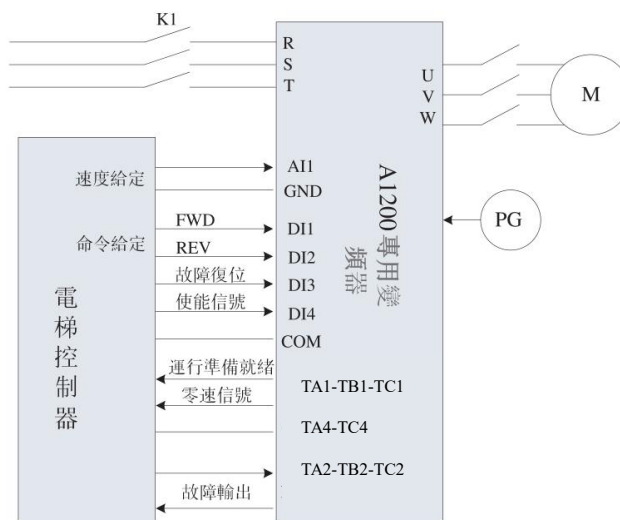

速度给定: Speed setting	故障复位: Fault reset	A1200 专用电梯变频器:
---------------------	-------------------	----------------

命令给定: Command setting 电梯控制器: Elevator Controller	使能信号: Enable signal 运行准备就绪: Running ready 零速信号: Zero speed signal 故障输出: Fault output	A1200 elevator inverter
---	---	-------------------------

Figure 7-5 Analog Control Wiring Diagram

7.2.2 Parameter setting

The motor autotuning method under the analog speed control mode is same to that of the preset speed control mode. Please conduct motor autotuning by reference to motor autotuning under preset speed control mode.

In the analog control system, the inverter, as a executor, will completely follow commands of the controller (as shown above) and the analog input signal is assumed as 0- +10V input. Following parameters need to be adjusted:

Description	Function Code	Name	Setting Value
Analog Function Parameter	P0-02	Speed	2
	P6-19	Corresponding Setting of Minimum Input of Analog	0
	P6-21	Corresponding Setting of Maximum Input of Analog	100
	P6-18	Minimum Input of Analog	0
	P6-20	Maximum Input of Analog	10
	P6-22	Analog Input Filter Time	0.1
Motor Encoder Parameter	P1 group and PA group	Acquired through motor autotuning. Please see the section of autotuning of synchronous and induction motor under preset speed control mode	
Vector Control Speed Loop Parameter	P2 group	Conduct regulation according to actual running features	
Input Terminal Defined Parameter (P4 Group)	P4-03	DI3 terminal function	7
	P4-04	DI4 terminal function 0	6

7.3 Inspection Running

Under preset speed control mode, A1200 elevator inverter has inspection running mode that has been processed correspondingly according to inspection running characteristics of the elevator. Control process and running curves will be briefly introduced below.

1) The inspection signal of inverter input terminals are enabled. After this signal is enabled, if the inspection signal (P6-16) is set as none zero value, the inverter will be forced to run under the preset speed selected by P6-16.

2) If the inspection speed is selected (P6-16) as non-zero value, and the setting preset speed value is equal to P6-16. If P6-16 is set as 1 and the preset speed 1 is selected for DI input, the inverter will enter the inspection mode even if there is no inspection signal input of input terminals.

With regards to slip test function, semi-automatic autotuning function and other functions that are enabled only under inspection mode, be sure to make the inverter enter the inspection mode before the system starts to running, otherwise these functions will be disabled.

7.3.1 System wiring diagram

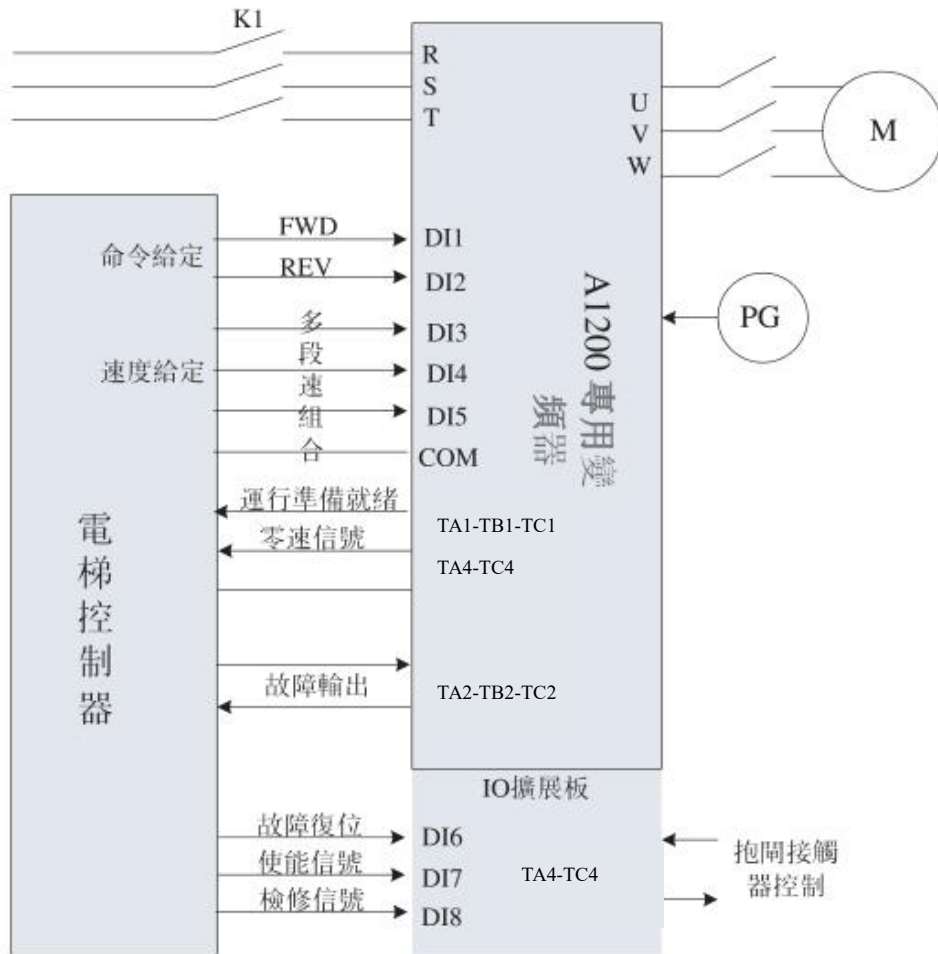

命令給定: Command setting	多段速組合: Preset speed	A1200 專用變頻器: A1200 elevator inverter
速度給定: Speed setting	運行準備就緒: Running ready	IO 擴展板: IO expansion board
电梯控制器: Elevator Controller	零速信號: Zero speed signal	抱閘接觸器控制: Brake contactor control
	故障輸出: Fault output	
	故障復位: Fault reset	
	使能信號: Enable signal	
	檢修信號: Inspection signal	

Figure 7-6 Inspection Running Wiring (Set DI8 as inspection signal input)

7.3.2 Parameter Setting and Running Curve Diagram

The main difference between the running sequence under inspection mode and normal mode is the stop process. For example, under the condition that P6-16=2, if elevator receives forward (reverse) command and signals of inspection input terminals, A1200 will run at the target frequency of preset speed 2 and the acceleration time is determined according to corresponding time curve of preset speed 2. During stop process, if inspection input signals are removed firstly, the system speed will decrease to 0 according to the deceleration time set by preset speed 2 until forward or reverse commands are canceled (As shown below, a shorter deceleration time period can be set, such as 1s, for ensuring the elevator can stop quickly).

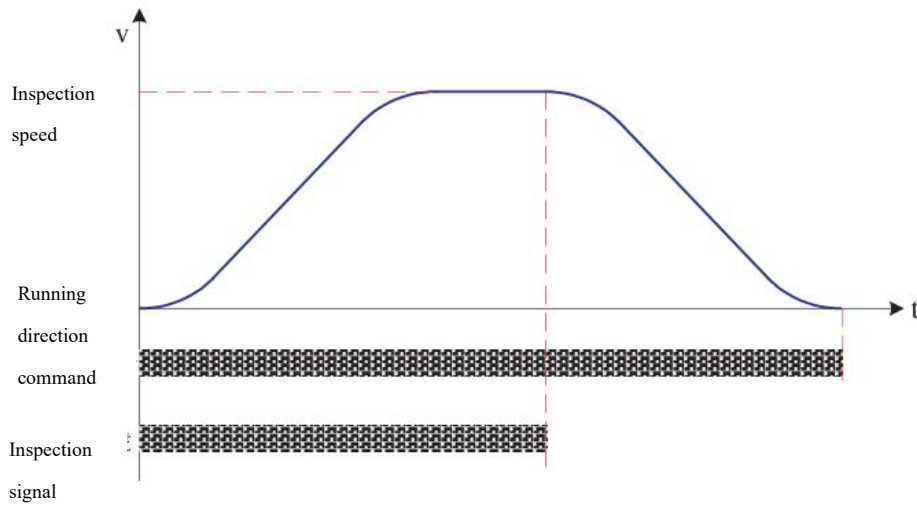

Figure 7-7 Inspection Signal Stop Sequence

The inverter will stop output immediately if the forward or reverse command is canceled during inspection running. See figure 7-8.

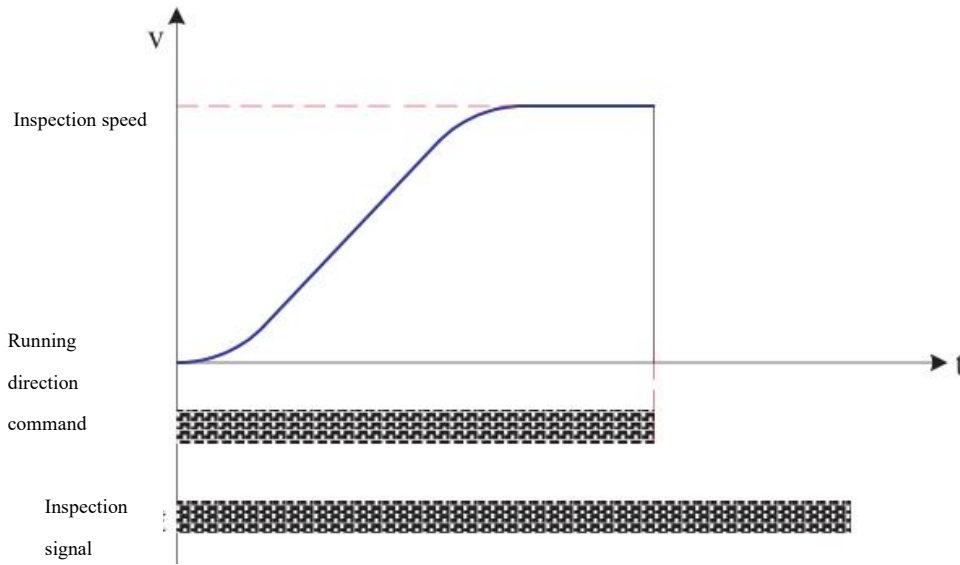

Figure 7-8 Stop Sequence Upon Removal of Direction Command during Inspection Running

If the preset speed 2 is adopted for inspection travel, the inspection running frequency is 10Hz and S curve 4 is selected, speed parameters for inspection running are as follows:

Function Code	Name	Setting Value	Default	Remarks
P6-05	Preset speed 2	10.00Hz	0.00Hz	Rated motor speed: 50.00Hz
P6-13	Acceleration/Deceleration Time of Preset Speed 2	4	1	
P6-16	Inspection Speed	2	0	Preset speed 2 is selected as inspection speed
P6-12	Acceleration Time 4	2.0s	20.0s	

P7-13	Deceleration Time 4	1.0s	20.0s	This parameter shall be small enough so as to ensure that the speed decreases to the minimum value before closing the brake.
-------	---------------------	------	-------	--

7.4 Power Failure Emergency Running

When the elevator is in operation, passengers may be trapped in the elevator in case of sudden system power failure.

A1200 elevator inverter adopts two types of power failure emergency running modes: UPS power supply and 48V battery supply

48V battery supply: The main circuit of the inverter adopts 48V battery as power supply while other parts of the elevator adopt UPS power supply(inverter power supply) above 220V as working power. So that the motor can run by battery power supply and requires less power supply.

UPS power supply: The inverter adopts UPS to provide power supply for its main circuit and operation in case of power failure.

Below introduces these two kinds of running modes: 48V battery power supply running and UPS power failure emergency running.

7.4.1 Power failure emergency running mode

1. System wiring diagram

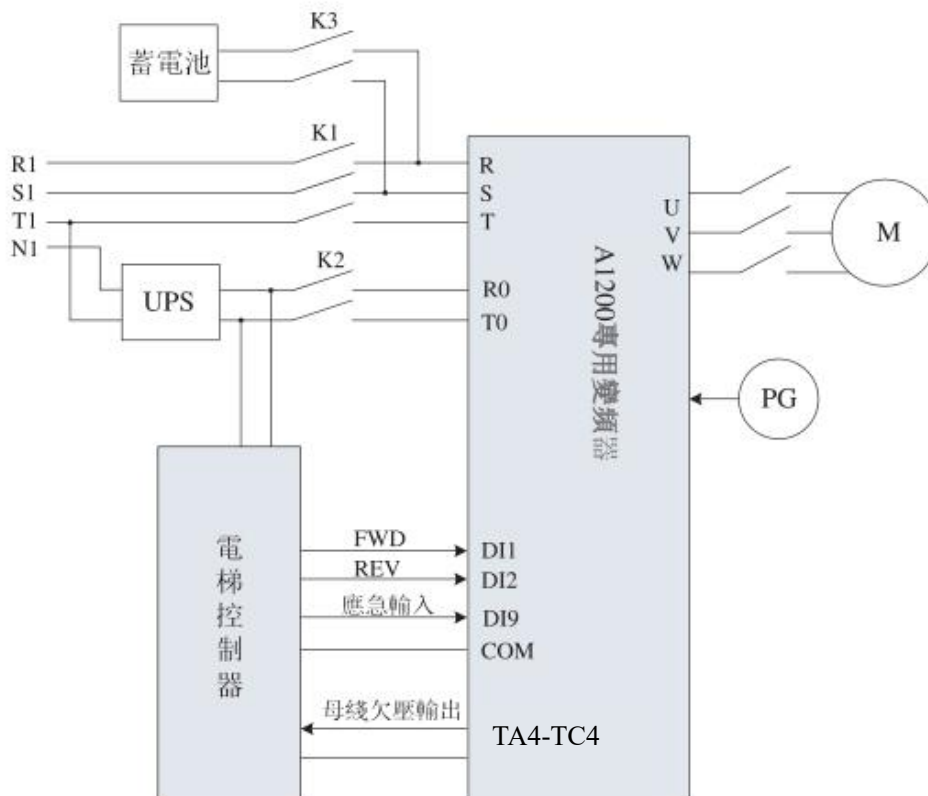

蓄電池: Battery

电梯控制器: Elevator controller

应急输入: Emergency input

母线欠压输出: Bus undervoltage output

A1200 专用变频器: A1200 series special elevator inverter

Figure 7-9 Battery Emergency Running Wiring Diagram

Note:

◆ For applying this mode, the inverter must be refitted and shall be equipped with UPS power supply interface R0 and T0.

2. Running sequence

Under the preset speed control mode, see figure 7-9 to conduct inverter wiring and DO2 shall be used as the bus undervoltage output terminal. Preset speed 2 is adopted as emergency running speed. Therefore, following function codes must be set under the preset speed control mode:

Function Code	Name	Setting Value	Default	Remarks
P4-09	DI9 Input	9	0	Emergency input
P5-02	TA4-TC4 Output	8	0	Bus undervoltage
P6-02	Preset Speed 2	2.00Hz	0.00Hz	Rated motor speed: 50.00Hz
P6-10	Preset Speed 2 S Curve	3	1	
P6-17	Power Failure Emergency Running	2	0	Select 48V battery for power supply
P7-08	Acceleration Time 3	30.0s	4.0s	Increase the acceleration time to avoid excessive impulse current

An example of running sequence when the elevator goes up is given below:

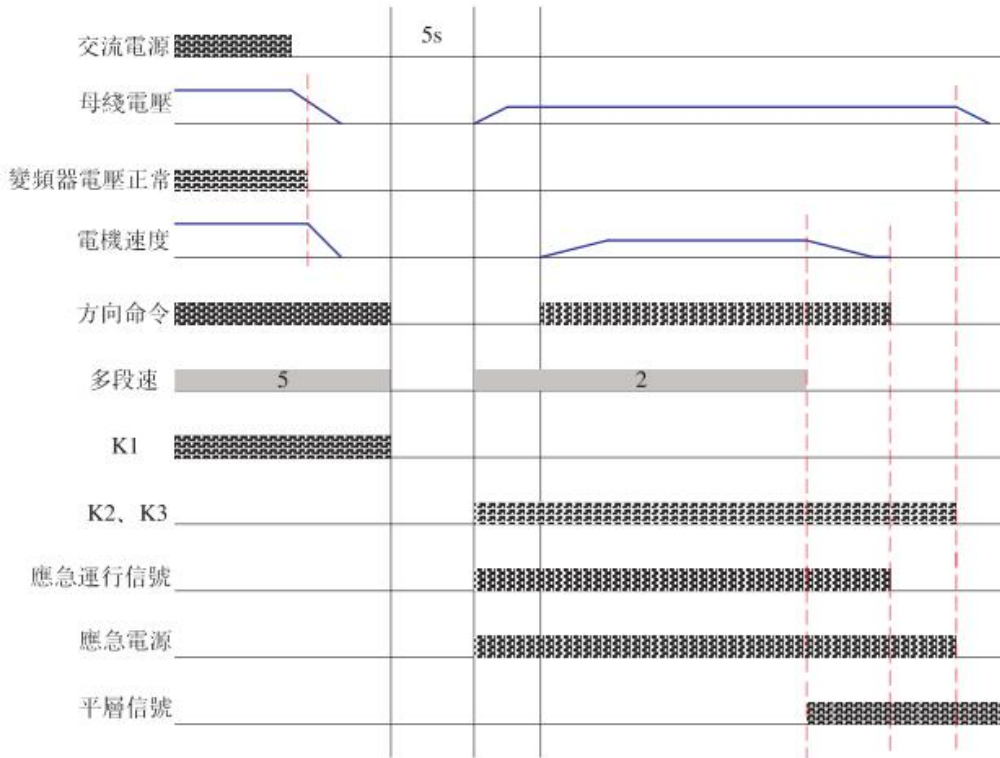

交流电源: AC power supply

母线电压: Bus voltage

变频器电压正常: Inverter voltage is normal

电机速度: Motor speed

方向命令: Direction command

多段速: Preset speed

K1

K2, K3

应急运行信号: Emergency running signal

应急电源: Emergency power supply

平层信号: Leveling signal

Figure 7-10 Emergency Running Sequence

Emergency running signal is provided by elevator controller and connected to the inverter through DI terminal. Through this signal, the inverter can judge if it is in emergency running status. Contactor K1, K2 and K3 are controlled by the elevator controller.

3. Attentions

1) Set the battery running speed and battery running acceleration/deceleration time properly according to actual conditions of the elevator. It is recommended to set the acceleration/deceleration above 10s. Running speed of battery is calculated according to the formula:

2) Battery running frequency $< (48V-5V) * \text{motor rated frequency} / (1.414 * \text{rated voltage})$

3) Input DC voltage 48V to the main circuit through the battery; use auxiliary power supply, such as UPS as working power supply;

4) It is recommended to set the stable output current of battery greater than the idling current of tractor;

5) The input terminal (DI) of A1200 elevator inverter is used to judge if the inverter is in emergency running status; at this time, the running speed of the inverter adopts preset speed and its corresponding acceleration/deceleration time is the acceleration/deceleration time of battery; the difference from normal running: During emergency running process, linear acceleration/deceleration is adopted as acceleration/deceleration mode;

6) During battery power supply running, the inverter will not detect the DC bus voltage. Therefore, when opening the brake, make sure the main circuit of the inverter has 48V voltage input;

7) During battery power supply running, the inverter will monitor speed and it will enable fault protection (Err32) in the event that the speed exceeds P6-28--Upper Limit of Power Failure Emergency Running Speed;

8) During emergency running, avoid running with load. Therefore, external controller shall select running with balanced load or brake load. With the function of "light load running and output", A1200 elevator inverter will output or shut down this signal according to load during normal running. Based on this signal, external controller can determine the emergency running direction.

9) During the operation process of power failure emergency running, attentions must be paid to the working sequence of contactors connected to the main power supply of the inverter and contactor connected to UPS. These two kinds of contactor can not be closed at the same time to avoid damages to UPS and battery.

7.4.2 UPS power failure emergency running mode

1. System wiring diagram

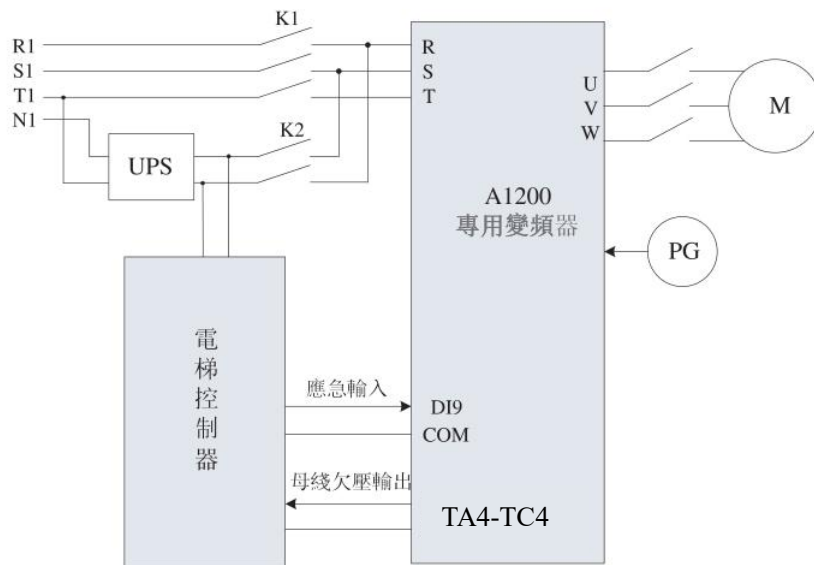

电梯控制器: Elevator controller
 A1200 专用变频器: A1200 elevator inverter
 应急输入: Emergency input
 母线欠压输入: Bus undervoltage input

Figure 7-11 UPS Emergency Running Wiring Diagram

2. Running sequence

When the inverter adopts UPS emergency running mode under the preset speed control mode. According to the figure above, configure:

- 1) Wiring of “emergency input” and “bus undervoltage output”;
- 2) Wiring between UPS and inverter under power failure status.

By taking preset speed 2 as emergency running speed, following function codes are required to be set:

Function Code	Name	Setting Value	Default	Remarks
P4-09	DI9 Input	9	0	Emergency input
P5-02	TA4-TC4 Output	8	0	Bus undervoltage
P6-02	Preset Speed 2	2.00Hz	0.00Hz	Rated motor speed: 50.00Hz
P6-10	Preset Speed 2 S Curve	3	1	
P6-17	Power Failure Emergency Running	1	0	Adopt UPS power supply
P7-08	Acceleration Time 3	30.0s	4.0s	Increase the acceleration time to avoid excessive impulse current

The operation sequence of UPS emergency running is identical to that of 48V emergency running. Similarly, UPS emergency running signal is provided by the elevator controller and connected to the inverter through DI terminal so the inverter can judge if it is in emergency running. Contactor

K1 and K2 are controlled by elevator controller.

7.5 Analog Weighing Debugging

In A1200 elevator inverter system, the forward command represents that the elevator will go up while reverse command represents that the elevator will go down. Based on this principle, the following analog weighing method is discussed.

7.5.1 Parameter Setting Method

If AI1 is adopted as pre-torque input channel, then set the parameter:

P3-09=2;

P3-10=elevator's balance coefficient.

Under idling car load, switch parameters on operation panel to check the sampling values (PU-17) and input it into P3-18; similarly, under full load, input the sampling values of AI1(PU-17) into P3-19. Two parameters above also can be determined through weighing autotuning .

Finally, regulate P3-11 to select appropriate compensation. P3-11 can be set as about 0.6 generally.

7.5.2 Debugging method for incorrect balance coefficient

On some situations, when the idling compensation is correct, the car load increase effect will be poor due to incorrect balance coefficient of the elevator.

If the balance coefficient is unclear, idling and full load compensation methods can be adopted to determine the balance coefficient (P3-10) and gain (P3-11) to ensure uniform system compensation effect.

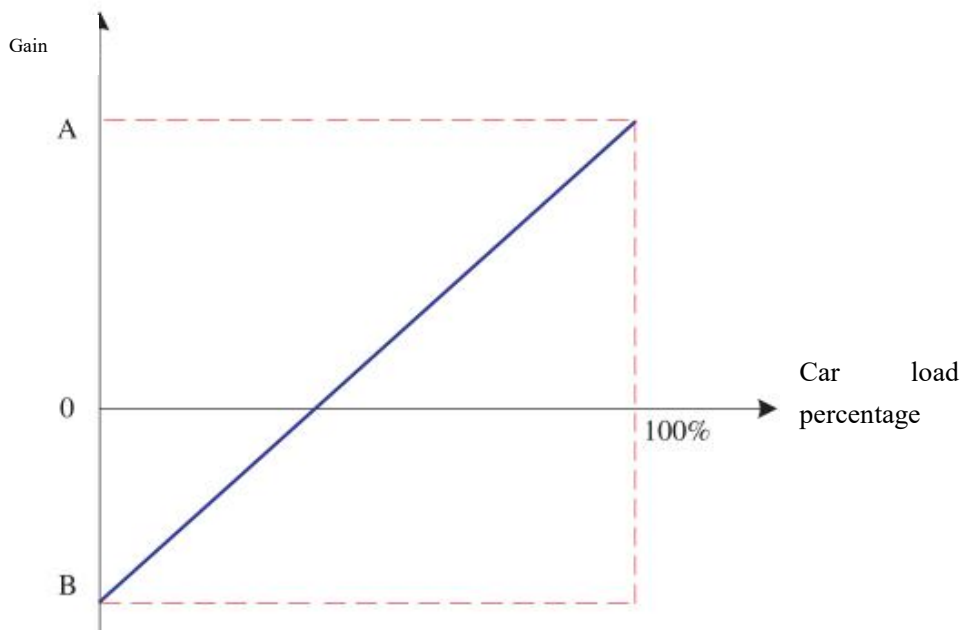

Figure 7-12 Compensation Curve

As shown in figure 7-12, firstly set P3-10 as 50% and conduct idling autotuning . Then, make the elevator go up and down and adjust P3-11 to observe if there exists motor slip phenomenon upon opening of brake. If there is no motor slip phenomenon and overtorque condition whether the elevator goes up or down under the motor torque compensation, record P3-11 as B(P3-11=B); then, fill the car with full load, conduct full-load autotuning , make the elevator go up and down and then adjust P3-11. Similarly, if compensation is appropriate, then P3-11=A.

As can be seen from the figure, the oblique line is the correct compensation curve of this elevator and the crosspoint of this oblique line and the horizontal shaft is the balance compensation point

of this elevator that corresponds to the elevator's balance coefficient. Based on the test, it can be calculated that:

$$P3-10=100*B/(A+B); P3-11=(A+B)/2;$$

For example, through idling test, it can be acquired that $B=0.7$; under full-load test, $A=0.4$; therefore, corresponding balance coefficient is set as $P3-10=36.4\%$, $P3-11=0.55$.

7.5.3 Debugging method for reverse running direction

If it has been set FWD corresponds to going down and REV corresponds to going up on the field, the method said above will make the compensation worse. The reason is that the direction is opposite. Under this condition, firstly record the sampling value P3-18 and P3-19 and the balance coefficient P3-10 under idling and full load conditions.

For example: $P3-18=X$; $P3-19=Y$; $P3-10=Z$; then setting parameters as follows to solve the problem:

$$P3-19=X; P3-18=Y; P3-10=100-Z.$$

7.6 Sensorless Debugging Method

7.6.1 Basic parameter setting

Parameter Description	Parameter	Setting Value
Encoder Type	P1-00	0
Weighing Mode	P3-09	5
Brake Opening Time (Zero Speed Holding Time)	P3-04	$>0.5s$

7.6.2 Instruction on debugging

Gradually increase the zero servo current factor (PD-05) until there is almost no slip phenomenon and no shaking of motor after the brake is opened;

During debugging, user can observe the slip condition under zero servo through parameter PU-20 and conduct regulation until the slip is not obvious;

If there exists obvious oscillation when the zero servo speed loop TI (PD-07) is less than 1.00, increase the zero servo current coefficient (PD-05);

Zero servo speed loop KP (PD-06) can be remained unchanged basically and shall not be excessive, otherwise it may result motor oscillation.

Chapter 8 Troubleshooting

8.1 Faults and Troubleshooting

A1200 elevator inverter has more than 50 warning messages and protection functions. In case of abnormality, it will enable protection and its output stops; the fault relay contact is on and fault code is displayed on the inverter display panel. Before seeking service, user can conduct examination by themselves according to this section to analyze fault causes and find solutions. If the fault still exists, please contact the agent from whom you purchase the inverter or directly contact our company for service.

◆ Note: Err33, Err16 and Err17 can not be reset and reset them after power cut

A1200 Series

Fault code	Fault Description	Possible Causes	Troubleshooting
Err02	Acceleration overcurrent	<ol style="list-style-type: none"> 1. Main circuit output grounded or short circuited 2. If motor parameter have been autotuned 3. Large load 4. Incorrect encoder signal 5. If UPS running feedback signal is normal 	<ol style="list-style-type: none"> 1. Check the output side of controller and the running contactor for abnormality 2. Check the power cables for surface damages and possibility of short circuit between the power cable and the group. Check if connection is reliable 3. Check if copper wire of the wiring terminal on the motor side is on the ground 4. Check if there short circuit or grounding wire inside the motor 5. Check if star-delta contactor results in output short circuit of the controller
Err03	Deceleration overcurrent	<ol style="list-style-type: none"> 1. Main circuit output grounded or short circuited 2. If motor parameter have been tuned 3. Large load 4. The deceleration curve is too abrupt 5. Incorrect encoder signal 	<ol style="list-style-type: none"> 6. Check if motor parameters are consistent with the nameplate 7. Conduct motor parameter autotuning again 8. Check if the brake is opened continuously before occurrence of fault 8. Check if any machine part is stuck 9. Check if the balance coefficient is correct 10. Check if relevant wiring of the encoder is correct and reliable. Induction motor can conduct open-loop operation and compare current to judge if the encoder works normally
Err04	Constant overcurrent	<ol style="list-style-type: none"> 1. Main circuit output grounded or short circuited 2. If motor parameter have been tuned 3. Large load 4. Large encoder interference 	<ol style="list-style-type: none"> 11. Check if the pulse count per rotation of the encoder is set properly 12. Check if encoder signals are interfered. 13. Check if the encode cables are aligned separately, if the wiring distance is too long; if the shielded layer is grounded with one end. 14. Check if the encoder is installed reliably, if the rotary shaft is connected to the motor shaft reliably, if it runs stably at high speed 15. Check if UPS feedback is enabled under non UPS running status. (Err02) 16. Check if the acceleration/deceleration speed is too large (Err02 and Err03)
Err05	Acceleration overvoltage	<ol style="list-style-type: none"> 1. Input voltage is too high 2. Serious elevator slip 3. Braking resistance is too large or braking units have fault 4. Acceleration curve is too 	<ol style="list-style-type: none"> 1. Adjust input power; observe if the bus voltage is normal and if it rises too fast during running 2. Check the balance coefficient 3. Select appropriate braking resistor; refer to

A1200 Series

		abrupt	the reference parameter table of braking resistor of Chapter 3 to observe if the resistance is too large 4. Check braking resistor wiring for damages and grounding wire. Check if the wiring is reliable.
Err06	Deceleration overvoltage	1. Input voltage is too high 2. Braking resistor is too large is too large or braking units have fault 3. Acceleration curve is too abrupt	
Err07	Constant overcurrent	1. Input voltage is too high 2. Braking resistor is too large is too large or braking units have fault	
Err08	Control power supply fault	1. Input voltage is too high 2. Driving control board runs abnormally	1. Adjust input power 2. Please contact the agent or manufacturer
Err09	Undervoltage fault	1. Power failure at the moment of power input 2. Input voltage is too low 3. Driving control board runs abnormally	1. Troubleshooting external power supply fault; check if the power supply is disconnected during running 2. Check if all power input cables are connected reliably 3. Please contact the agent or manufacturer
Err10	Inverter overload	1. Brake circuit has abnormality 2. The load is too large 3. If the encoder feedback signals are normal 4. If motor parameters are normal 5. Check the motor power wires	1. Check the brake circuit and power supply 2. Reduce load 3. Check if the encoder feedback signals and setting are correct and if the initial angle of the synchronous motor encoder is correct 4. Check relevant motor parameters and conduct autotuning 5. Check relevant power cables of motor (see troubleshooting of Err02)
Err12	Input phase loss protection	1. Input power supply is asymmetric 2. Driving control board has abnormality	1. Check if the 3-phase power supply of the input side is balanced, if the power supply voltage is normal. Adjust the input power supply. 2. Please contact the agent or manufacturer
Err13	Output phase loss protection	1. Output wiring of main circuit is loose 2. Motor damages	1. Check wiring 2. Check if the contactor of output side is normal 3. Troubleshooting motor fault
Err14	Radiator overheating	1. Ambient temperature is too high 2. Fan fault 3. Air duct is blocked	1. Lower the ambient temperature 2. Clean the air duct 3. Replace the fan 4. Check if the installation distance of the controller meets the requirements of Chapter 3

A1200 Series

Err15	External fault or output side abnormality	<ol style="list-style-type: none"> 1. Elevator controller fault 2. Braking output side is short circuited 3. UVW output side works abnormally 	<ol style="list-style-type: none"> 1. Check if the elevator controller works normally 2. Check if the braking resistance and the wiring of braking units are connect and ensure there is no short circuit 3. Check if the main contactor works normally 4. Please contact the manufacturer or the agent
Err16	Current control fault	<ol style="list-style-type: none"> 1. Excitation current deviation is too large 2. Torque current deviation is too large 3. Exceeding the torque limitation time 	<ol style="list-style-type: none"> 1. Check the encoder circuit 2. Output air switch is switched off 3. Current loop parameter is too small 4. The zero point position is incorrect and conduct autotuning again 5. The load is too large
Err17	Encoder reference signal abnormality	<ol style="list-style-type: none"> 1. Deviation between Z signal reach and the absolute position is too large 2. The deviation between the absolute position angle and Accumulated angles is too large 	<ol style="list-style-type: none"> 1. Check if the encoder works normally 2. Check if the encoder wiring is reliable and normal 3. Check if the PG card wiring is correct 4. Check if the control cabinet and master are grounded properly
Err18	Current detection fault	Driving control board fault	Please contact the manufacturer or the agent
Err19	Motor autotuning fault	<ol style="list-style-type: none"> 1. Motor can not run normally 2. Parameter autotuning overtime 3. Rotary encoder of synchronous motor has abnormality 	<ol style="list-style-type: none"> 1. Input motor parameters correctly 2. Check if the motor wiring and contactor of output side have phase loss 3. Check the wiring of rotary encoder to confirm if the pulse count per rotation is correct 4. Under autotuning without load, check if the brake is opened 5. During autotuning for synchronous motor with a load, if the inspection running button is released before autotuning is completed.
Err20	Speed feedback error and fault	<ol style="list-style-type: none"> 1. AB signals are lost during autotuning 3: Motor wires are connected inversely 4: Z signal 5 can not be detected during autotuning process: SIN_COS encoder CD is disconnected 7: UVW disconnection of UVW encoder 	<ol style="list-style-type: none"> 1, 4, 5, 7, 8, 10, 11, 13, 14, 19: Check signal wiring of all phases of the encoder; 3: Please exchange the sequence of any two phases of 3 phase UVW of the motor; 9: If the synchronous motor P1-00/12/25 is set correctly; 12: Check if any mechanical parts are stuck during running; check if the brake is opened; 55: Check the earthing condition and deal with interference.

A1200 Series

		<p>8: Angle deviation is too large</p> <p>9: Overspeed or the speed deviation is too large</p> <p>10, 11: AB or CD signals of SIN_COS encoder are interfered</p> <p>12: Torque limit, the testing speed is 0</p> <p>13: AB signals lost during running</p> <p>14: Z signals lost during running</p> <p>19: AB analog signal is disconnected during low-speed running process</p> <p>55: CD signals error or Z signal error caused by serious interference during autotuning</p>	
Err21	Parameter setting error	Maximum frequency is lower than rated frequency	Check if the maximum frequency is lower than the rated frequency
Err23	Protection of short circuit to earth	Short circuit between output and the ground	<ol style="list-style-type: none"> 1. Check if there exists short circuit between the motor or contactor of output side and the ground 2. Please contact the agent or manufacturer
Err24	RTC clock fault	101: Time information abnormality of control board	101: Replace the clock battery; replace the master control panel
Err25	Data storage fault	101, 102: Data storage fault of master control panel	101, 102: Please contact the agent or manufacturer
Err32	Emergency running overspeed	The speed exceeds the setting value during battery running (P6-28)	<ol style="list-style-type: none"> 1. Check if the battery voltage is normal 2. Check if wires are loose 3. Check if P6-28 is set too small
Err33	Overspeed fault	The running speed of the inverter exceeds the overspeed judgment level and the average Accumulated time is greater than overspeed judgment time	<ol style="list-style-type: none"> 1. Check if the motor power is matched 2. Check if the elevator load is too heavy 3. Check if the rotary encoder signals are correct 4. Check if the parameter PC-09 and PC-10 are set too harsh.
Err34	Speed deviation is too large	The inverter feedback frequency and the setting frequency exceed the setting range, and the lasting time is greater than the setting time	<ol style="list-style-type: none"> 1. Check if the motor power is matched 2. Check if the elevator load is too heavy 3. Check if the rotary encoder signals are correct 4. Check if the parameter PC-12 and PC-13 are set too harsh.
Err36	Contactor fault	<ol style="list-style-type: none"> 1. Contactor feedback signals are enabled before the contactor is started 2. There is no feedback signal 	<ol style="list-style-type: none"> 1. Check if the contact and feedback contact are normal 2. Check if functions of inverter input point are set correctly

		before the contactor is closed	3. Check if the control circuit power supply of contactor are normal
Err37	Brake fault	Brake output is inconsistent with feedback signals, lasting for more than 2s	1. Check if the brake coil and feedback contact are normal 2. Confirm the signal characteristics of feedback contact (normally open and normally closed) 3. Check if the control circuit power supply of the brake coil is normal
Err38	Contact adhesion	During stop status, feedback signal of brake or running contactor is enabled continuously for more than 2.5s	1. Check wiring 2. Check the brake and running contactor
Err39	Motor overheating	Motor overheating signal is enabled	1. Check if the motor runs correctly and if there exists motor damage 2. Improve the radiation conditions of the motor
Err40	Elevator running conditions do not meet requirement	The setting running time of the elevator is out	1. The elevator has been used for a long time, and maintenance and service are required.
Err55	DSP communication protection	Abnormality of wiring of drive board and control board	1. Check the cables between the driver board and logic board

8.2 Common Faults and Handling Methods

The inverter may have following faults during running. Please analyze fault simply according to following methods:

1. No display after power-on:

- 1) Use multimeter to check if the input power of the inverter is consistent with the rated voltage of the inverter. In case of power supply fault, check and troubleshoot the fault.
- 2) Check if the 3-phase rectifier bridge is intact. If the rectifier bridge breaks, please seek for professional service.
- 3) Check if the CHARGE indicator is on. If it is off, the fault generally occurs at the rectifier bridge or buffer resistance. If this indicator is on, the fault may occur at the switch power supply. Please seek for professional service.

2. Power supply air switch tripping after power-on:

- 1) Check if input power supply are grounded or short circuited, and troubleshoot the fault.
- 2) Check if the rectifier bridge has been broken down. In case of damages, please seek for professional service.

3. The motor doesn't run after the inverter runs:

- 1) Check if there exists balanced 3-phase output between U, V and W. If any, there exists

damages of motor cables or the motor or the motor rotor is blocked due to mechanical causes. Please troubleshoot the fault.

2) If there is output but the output is unbalanced between 3-phase, the inverter drive board or output module may have damages. Please seek for professional services.

3) If there is no voltage output, the drive board or output module may be damaged, so please seek for professional service.

4. After power on, the inverter displays normally but the power supply air switch trips after the inverter runs:

1) Check if there is short circuit between phases of output modules. If any, please seek for professional service.

2) Check if there is short circuit or grounding in motor cables. If any, please troubleshoot it.

3) If tripping happens occasionally and motor is located far away from the inverter, output AC reactor shall be installed.

Chapter 9 Specification

9.1 Major Parameters of A1200 Series Inverter

Table 9.1 Major Parameters of A1200 Inverter

A1200 Model	Input Voltage	Power Capacity(kVA)	Input Current (A)	Output Current (A)	Applicable Motor (kW)
A1200-2R2-43A	3-phase 380V Range: -15%-20%	4.0	6.5	5.1	2.2
A1200-3R7-43A		5.9	10.5	9.0	3.7
A1200-5R5-43A		8.9	14.8	13.0	5.5
A1200-7R5-43A		11.0	20.5	18.0	7.5
A1200-011-43A		17.0	29.0	27.0	11.0
A1200-015-43A		21.0	36.0	33.0	15.0
A1200-018-43A		24.0	41.0	39.0	18.5
A1200-022-43A		30.0	49.5	48.0	22.0
A1200-030-43A		40.0	62.0	60.0	30.0
A1200-037-43A		57.0	77.0	75.0	37.0
A1200-045-43A		69.0	93.0	91.0	45.0

9.2 Technical Specification

Table 9.2 Technical Specification of A1200 Inverter

Item	Specification
Carrier frequency	2kHz-16kHz; Automatically adjust the carrier

A1200 Series

General Specification		frequency according to load characteristics		
	Input frequency resolution	Digital setting: 0.01Hz Analog setting: Maximum frequency $\times 0.1\%$		
	Output frequency accuracy	Digital setting: Maximum frequency $\times \pm 0.01\%$ Analog setting: Maximum frequency $\times \pm 0.01\%$		
	Control mode	Closed-loop vector control (SVC)/ open-loop vector control (VC)/VF control		
	Start torque	0.5Hz/180% (SVC); 0Hz/200% (VC)		
	Speed regulation range	1:100(SVC)	1:1000(VC)	1:50 (V/F)
	Steady speed accuracy	$\pm 0.5\%$ (SVC)	$\pm 0.05\%$ (VC)	
	Overload capacity	150% rated current for 60s; 180% rated current for 1s.		
	Motor autotuning	Autotuning for a motor with load; autotuning for a motor without load		
	Acceleration/deceleration curve	Linear or S curve acceleration/deceleration mode; four groups of acceleration/deceleration time and four groups of S curve setting; multiple combination		
	Inspection control	Specified by any preset speed		
	Preset speed running	Running of maximum 8 preset speeds is realized		
Automatic voltage regulation (AVR)	In case of voltage change of power grid, it can automatically keep output voltage constant			
	LED display	Setting frequency, output frequency, output voltage, output current and other parameters can be displayed		
	Parameter copy	With LED operational panel, rapid replication of parameters can be realized		
	Protection function	40 kinds of protection, such as electric short circuit detection, input and output phase loss protection, overcurrent protection, overvoltage protection, undervoltage protection.		
	Keys locking and function	Lock all or part of keys, and define the function of some keys to avoid misoperation		
Special Features	Self-check of peripheral equipment after power on	Conduct safety detection to peripheral equipment after power-on, such as earthing and short circuit.		
	Power failure emergency running	Emergency running scheme is simple and convenient		
	Overspeed protection	With elevator overspeed protection function; multiple action options		
	Speed deviation judgment	With speed deviation detection function; find potential risks of the elevator in a timely manner		
	Forced speed change function	With the function of forced speed change detection; effectively prevent the elevator from		

A1200 Series

		rushing to the top or collapsing to the bottom
	Direct stop function	Combined with the direct stop command, this function can make the elevator run without crawl phenomenon
	Elevator temperature detection	Judge the motor temperature timely and eliminate safety risks
	Start compensation	Three types of start torque compensation modes: Analog, digital, no-weighing
	Timer control	Timer control function can be realized conveniently
Input and Output Characteristics	Running command channel	Two channels: Operation panel setting, control terminal setting
	Frequency source	Four kinds of frequency source: numeric setting, preset speed setting, analog voltage 1 setting and analog voltage 2 setting
	Input terminal	10 numeric input terminals. One of them can be used as high-speed pulse input. Compatible with PNP 2 analog input terminals. One of them can be used as voltage input, another can be used as voltage or current input.
	Output terminal	4 relay output terminal 1 analog output terminal, 0/4-20mA or 0/2-10V optional respectively. Setting frequency, output frequency and physical quantity output can be realized.
Environment	Altitude	Lower than 1000m (if above 1000m, derating 1% per 100m)
	Ambient temperature	-10℃ -+40℃ (ambient temperature is within 40℃ -50℃, it must be derated)
	Humidity	Lower than 95%RH, no water condenses
	Vibration	Less than 5.9m/s ² (0.6g)
	Storage temperature	-20℃ -+60℃

A1200 Series

Appendix 1 Braking Unit Options Guide

With regards to A1200 elevator inverter, inverter models with power below 30kW(30kW inclusive) have built-in braking units. Users are only required to connect it to external braking resistor. Inverter models with power above 30kW shall be configured with external braking units and braking resistor.

List of Braking Units of A1200 Series Special Elevator Inverter

Inverter Model	Applicable Motor (kW)	Maximum Braking Resistance (Ω)	Minimum Braking Resistance(Ω)	Power (W)	Braking Unit
A1200-2R2-4 3A	2.2	290	230	600	
A1200-3R7-4 3A	3.7	170	135	1100	
A1200-5R5-4 3A	5.5	115	90	1600	
A1200-7R5-4 3A	7.5	85	65	2500	
A1200-011-4 3A	11	55	43	3500	
A1200-015-4 3A	15	43	35	4500	
A1200-018-4 3A	18.5	34	25	5500	
A1200-022-4 3A	22	24	22	6500	
A1200-030-4 3A	30	20	16	9000	
A1200-037-4 3A	37	16	13	11000	CDBR-3744
A1200-045-4 3A	45	14	11	13500	CDBR-4544